

Supersedes edition 11/29/2013



LED INSET TAXIWAY CENTRELINE, STOP BAR AND INTERMEDIATE HOLDING POSITION LIGHT

LTA04

INSTRUCTION MANUAL FOR USE, INSTALLATION AND MAINTENANCE

Compiled by: Nicola Marabini

Approved by: Piero Scaramagli

N° Attachments: 1

Copy n°:

Edition 11/03/2014

Supersedes edition 11/29/2013

LED INSET TAXIWAY CENTRELINE, STOP BAR AND INTERMEDIATE HOLDING POSITION LIGHT LTA04
INSTRUCTION MANUAL FOR USE, INSTALLATION AND MAINTENANCE

LIMITED PRODUCT WARRANTY

THE FOLLOWING WARRANTY IS EXCLUSIVE AND IN LIEU OF ALL OTHER WARRANTIES, WHETHER EXPRESS, IMPLIED OR STATUTORY, INCLUDING, BUT NOT BY WAY OF LIMITATION, ANY WARRANTY OF MERCHANTABILITY OR FITNESS FOR ANY PARTICULAR PURPOSE.

OCEM - ENERGY TECHNOLOGY warrants to each original Buyer of Products manufactured by the Company that such Products are at the time of delivery to the Buyer, free of material and workmanship defects, provided that no warranty is made with respect to:

- (a) any Product, which has been repaired or altered in such a way, in Company's judgement, as to affect the Product adversely;
 - (b) any Product which has, in Company's judgement, been subject to negligence, accident or improper storage;
 - (c) any Product which has not been operated and maintained in accordance with normal practice and in conformity with recommendations and published specification of Company;
 - (d) the breaking of the warranty seals, if present, determines the immediate termination of the warranty;
- and,

OCEM - ENERGY TECHNOLOGY's obligation under this warranty is limited to use reasonable efforts to repair or, at its option, replace, during normal working hours at the facility of the Company, any Product which in its judgement proved not to be as warranted within the applicable warranty period. All costs of transportation of Products claimed not to be warranted and of those repaired or replaced, to or from the facility of the Company shall be borne by Purchaser. Company may require the return of any Product claimed not to be as warranted to its facility, transportation prepaid by Purchaser, to establish a claim under this warranty. The cost of labour for the installation of a repaired or replaced Product shall be borne by Purchaser. Replacement parts provided under the terms of this warranty are warranted for the remainder of the warranty period of the Products upon which they are installed to the same extent as if such parts were original components thereof. Warranty services provided under the Agreement do not assure uninterrupted operations of Products; Company does not assume any liability for damages caused by any delays involving warranty service.

IMPORTANT: READ THIS DOCUMENT

Before proceeding to the operations of installation, commissioning, operation, maintenance or disposal, carefully read the entire document.

SAFETY INFORMATION

Extreme caution should be exercised when working with this equipment; it is normally used or connected to circuits that operate at dangerous voltages and can be fatal.

The following section contains important safety information that you must follow when installing and using the apparatus.

Misuse of the equipment or lack of care in applying safety procedures and prescriptions specified in this document, may result in a hazard.

Avoid contact with voltage or current sources.

For no reason the protections and the safety devices must be removed.

Edition 11/03/2014

Supersedes edition 11/29/2013

LED INSET TAXIWAY CENTRELINE, STOP BAR AND INTERMEDIATE HOLDING POSITION LIGHT LTA04
INSTRUCTION MANUAL FOR USE, INSTALLATION AND MAINTENANCE

OPERATION ON THE EQUIPMENT - SKILLS

Operation on the equipment and access to its internal parts shall be done by experienced personnel, adequately trained and aware of the risks related to electricity and high voltages.
Safety rules shall be adopted when operating on the equipment, or on cables and other apparatus connected to the it

DO NOT OPERATE ON ENERGIZED CIRCUITS

Do not carry out any operation on the converter or on apparatus connected to it when the circuits are energized.

WHEN HANDLING AND SERVICING THIS EQUIPMENT, OBSERVE PRECAUTIONS FOR HIGH VOLTAGE EQUIPMENT.

Before any access, inspection or intervention, be sure to have switched-off the unit, opened the main circuit breaker and removed the supply to the unit (by opening the circuit breaker/switch on the distribution board at the beginning of the supply line).

Then wait discharge time (at least 5 minutes), ground carefully the system, and check for voltage presence before accessing..

REANIMATION

The maintenance staff must be aware of the risks related to electricity, criteria to prevent the risk of electric shock and resuscitation techniques

CE MARK



This equipment complies with the requirements of European regulations for the CE mark. The user has to respect all prescriptions reported in this document.

This equipment complies with the requirements of the EEC directives 2004/108/EEC and 2006/95/EEC with regard to "Electromagnetic Compatibility" and "Low Voltage Electrical Apparatus" respectively.

OUT OF SERVICE

In case of dismantling, decommissioning, destruction, disposal, the user shall follow all the required precautions for component and material elimination, according to local rules and applicable law.

Edition 11/03/2014

Supersedes edition 11/29/2013

LED INSET TAXIWAY CENTRELINE, STOP BAR AND INTERMEDIATE HOLDING POSITION LIGHT LTA04
INSTRUCTION MANUAL FOR USE, INSTALLATION AND MAINTENANCE

EDITIONS

Date

06/10/2013	First issue
29/11/2013	Updated § "List of the recommended spare parts"
03/11/2014	New address of the Company Updated the P/N identification Deleted § "List of the recommended spare parts" and added relevant attachment

REVISIONS

Index	Date	Description	Edited by	Approved by
--------------	-------------	--------------------	------------------	--------------------

LIST OF EFFECTIVE PAGES

From page 1 to page 43

INDEX

LIMITED PRODUCT WARRANTY.....	2
SAFETY INFORMATION	2
EDITIONS	4
REVISIONS.....	4
LIST OF EFFECTIVE PAGES.....	4
INDEX.....	5
INDEX OF FIGURES.....	6
INDEX OF TABLES.....	7
LIST OF ATTACHMENTS	7
1 GENERAL.....	8
2 MAIN FEATURES	8
2.1 REMOVABLE LIGHT UNIT.....	8
2.1.1 Dome.....	9
2.1.2 Optical Assembly.....	9
2.1.3 Power Supply/Control Board	10
2.1.4 Lower Cover	10
2.2 SHALLOW BASE	16
2.3 ELECTRONIC SECTION.....	17
2.3.1 Current / current conversion circuit (patented).....	17
2.3.2 LED command circuit	18
2.3.3 Control circuit	18
2.4 ARCTIC KIT	18
3 INSTALLATION	19
3.1 PAVEMENT BORING AND SAWCUTTING.....	19
3.1.1 Scheme of Light Configurations	20
3.2 CURVED SECTION LIGHT ALIGNMENT.....	21
3.3 INSTALLING THE SHALLOW BASE	23
3.4 INSTALLING THE LIGHT UNIT ON L-868 BASE, SIZE B	28
3.5 SECONDARY WIRING	29
4 MAINTENANCE	30
4.1 MAINTENANCE PROGRAM	30
4.1.1 Periodical Checks	30
4.1.2 Snowplow Operations.....	31
4.1.3 Removing the fixture	31
4.1.4 Opening the fixture.....	31
4.1.5 Closing the fixture	31
4.1.6 Leakage test	32
4.1.7 Reinstalling the fixture.....	32
4.2 PRIMS CLEANING.....	33
4.2.1 Prism outside cleaning.....	33

Edition 11/03/2014

Supersedes edition 11/29/2013

LED INSET TAXIWAY CENTRELINE, STOP BAR AND INTERMEDIATE HOLDING POSITION LIGHT LTA04
INSTRUCTION MANUAL FOR USE, INSTALLATION AND MAINTENANCE

4.2.2 Prism inside cleaning.....	33
4.3 PRISM REPLACEMENT	34
4.3.1 Removing the Prism	34
4.3.2 Installing the New Prism	35
4.4 LED MODULE REPLACEMENT	35
4.5 ELECTRONICS REPLACEMENT	36
4.6 ARCTIC KIT REPLACEMENT	37
4.6.1 Thermostat.....	37
4.6.2 Heater.....	37
4.7 GASKETS.....	38
4.7.1 Gasket examination	38
4.7.2 O-Ring replacement	40
4.8 CABLE LEAD WITH PLUG.....	40
4.8.1 Removing the cable lead with plug.....	40
4.8.2 Installing the new cable lead with plug	40
4.9 PRESSURE VALVE	41
4.10 CLEANING	42
4.11 MONITORING	42
5 TROUBLESHOOTING	43

INDEX OF FIGURES

Figure 1 – 8” Dome outside view	9
Figure 2 – Lower Cover Outside View	11
Figure 3 – Lower Cover Inside View	11
Figure 4 – Wiring Diagram.....	12
Figure 5 – Exploded View	13
Figure 6 – Part List.....	14
Figure 7 - Complete P/N identification.....	15
Figure 8 – Gasket of 8” fixture for 8” shallow base.....	16
Figure 9 – Standard 8”-12” shallow base	17
Figure 10 – Pavement Boring, Sawcutting and Joint Intersection Details	19
Figure 11 – Taxiway Centreline (ICAO) Scheme of Light Configurations	20
Figure 12 – Stop Bar (ICAO) Scheme of Light Configurations	21
Figure 13 – Curved section light alignment.....	22
Figure 14 – Gaskets for 8” shallow base	25
Figure 15 – Gaskets for 12” shallow base	26
Figure 16 – 8” shallow base for side or bottom ducts (method “B”).....	26
Figure 17 – 12” shallow base for side or bottom ducts (method “B”).....	27
Figure 18 – Shallow base installation details	27
Figure 19 – Optical device (refer to the manual UT-MT-0485 for further information)	28
Figure 20 – Gaskets for L-868 base	29
Figure 21 - Lower Cover Fixing Screws	32
Figure 22 - Lower Cover with Pressure Valve.....	32

Edition 11/03/2014

Supersedes edition 11/29/2013

LED INSET TAXIWAY CENTRELINE, STOP BAR AND INTERMEDIATE HOLDING POSITION LIGHT LTA04
INSTRUCTION MANUAL FOR USE, INSTALLATION AND MAINTENANCE

Figure 23 – Fixture Gaskets	33
Figure 24 – Prism Surface to be Cleaned	34
Figure 25 - Prism Replacement	35
Figure 26 – LED Module Replacement	36
Figure 27 – Wiring diagrams for the heaters	38
Figure 28– Fixture Gaskets	39
Figure 29 – Prism Gasket.....	39
Figure 30 - Cable Lead With Plug	41
Figure 31 - Lower Cover with Pressure Valve	41
Figure 32 - Restoring the Monitoring Device	42

INDEX OF TABLES

Table 1 - Use and compliance	15
Table 2 - Taxiway centreline longitudinal spacing according to FAA.....	22
Table 3 - Taxiway centreline longitudinal spacing according to ICAO	22

LIST OF ATTACHMENTS

UC-PU-0283 - LIST OF THE RECOMMENDED SPARE PARTS

Edition 11/03/2014

Supersedes edition 11/29/2013

LED INSET TAXIWAY CENTRELINE, STOP BAR AND INTERMEDIATE HOLDING POSITION LIGHT LTA04
INSTRUCTION MANUAL FOR USE, INSTALLATION AND MAINTENANCE

1 GENERAL

LTA04 inset LED taxiway centreline light is medium intensity, bidirectional or unidirectional, 8" or 12" steady burning type.

These fixtures are intended for use as taxiway centreline, stop bar (ICAO) and intermediate holding position (ICAO) light, in order to provide a visual aid to the moving aircraft.

LTA04 lights are in compliance with ICAO Annex 14 Vol.1, FAA AC 150/5345-46 (Style 3), IEC TS 61827 (Style 4) and NATO-STANAG 3316.

The fixtures described in this manual are designed to be connected to series circuit, replacing those equipped with incandescent lamps, fed through standard isolation transformers connected to CCR with variable current from 2.8 A to 6.6 A.

Location of these fittings shall be in compliance with ICAO - Annex 14, STANAG 3316 and FAA

2 MAIN FEATURES

Each light assembly consists of a removable fixture and a shallow base receptacle. The fixture is waterproof and designed to withstand aircraft impact and roll-over loads without damage.

On request, for 8" fixture, a suitable adaptor ring (base mounted, option R) is available to allow the installation on shallow base, 12" diameter, or on deep base, type L-868, size B, as per FAA AC 150/5345-42, thereby permitting replacement of any inset fixture without removing the deep base from the pavement.

The fixture can be bidirectional type (bidirectional dome equipped with two LED modules, operating at the same time or independently) or unidirectional type (unidirectional dome equipped with only one LED module); otherwise in case of bidirectional fixture the light beam can be symmetric (two opposite beams) or asymmetric (toe-in beams for taxiway curved section in accordance with ICAO – Annex 14 and STANAG 3316 ed FAA).

It is also possible to obtain an unidirectional light from a bidirectional dome choosing the 'X – Screened' option ; this configuration includes a bidirectional dome mounting only one LED module.

Power consumption for bidirectional fixture is 12 VA (1 plug) and 14 VA (2 plugs), unidirectional fixture is 67 VA (1 plug).

2.1 REMOVABLE LIGHT UNIT

The removable fixture mainly consists of a dome, an optical assembly, a power supply/control board, and a lower cover.

Edition 11/03/2014

Supersedes edition 11/29/2013

LED INSET TAXIWAY CENTRELINE, STOP BAR AND INTERMEDIATE HOLDING POSITION LIGHT LTA04
INSTRUCTION MANUAL FOR USE, INSTALLATION AND MAINTENANCE

2.1.1 Dome

The dome is made of treated drop-forged aluminium and includes one or two windows to seat the prisms, complete with gaskets, kept in the proper position by means of a mounting plate fixed with HSCS M5x12 screws. In correspondence of the windows, the dome is outside provided with identification letters "A" and "B".

The dome is provided with two (8") or six (12") through holes for fastening the light unit to the base. Only for 8" fixtures two dead holes are provided on the dome in order to match two studs mounted on the base, so to prevent the rotation of the light unit due to aircraft wheel impact/roll over.

It is also provided with two suitable slots, in opposite position, to make easy the fixture removal by using two suitable lifting tools (available on request, P/N 332.4140 or 332.4230). As alternative, two screwdrivers can be used.

A silicone O-Ring (separately supplied) has to be mounted outside around the dome, to avoid dirt deposits between dome and shallow base.

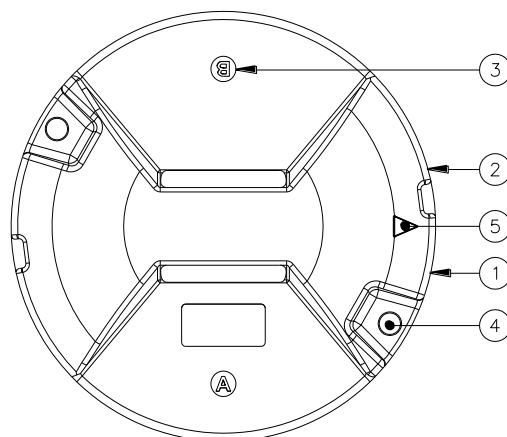

1. Dome
2. Slot for dome removal
3. Letter "A" to identify the beam
4. Through hole for light unit fastening
5. Reference arrow

Figure 1 – 8" Dome outside view

2.1.2 Optical Assembly

The **optical assembly** consists of two prisms (Figure 5 - n°5) with relevant gaskets (Figure 5 - n°4) and two LED module (Figure 5 - n°12) with reflector (Figure 5 - n°13) kept into the proper position by mounting plate (Figure 5 - n°7). Unidirectional fixtures mount only one prism and one LED module.

Fixtures can be provided with four kind of prisms in order to obtain four different configurations:

- Straight sections ICAO, STANAG 3316 and FAA L-852A/C
- Curved sections FAA L-852B/D
- Curved sections (right) ICAO, FAA type L-852J/K and STANAG 3316

Edition 11/03/2014

Supersedes edition 11/29/2013

LED INSET TAXIWAY CENTRELINE, STOP BAR AND INTERMEDIATE HOLDING POSITION LIGHT LTA04
INSTRUCTION MANUAL FOR USE, INSTALLATION AND MAINTENANCE

- Curved sections (left) ICAO, FAA type L-852J/K and STANAG 3316

Each LED module consists of three LEDs mounted on a metal core PCB, coupled with the support through thermo conductive material; the reflector is fixed to the support assembly.

All the optical assembly parts are factory assembled; they may be field-replaced if necessary.

2.1.3 Power Supply/Control Board

The power supply/control board is encapsulated into waterproof and heat conductive silicon resin.

The PCB powers and controls the LEDs so that the light output provided at every current step from 2.8 A to 6.6 A is comparable to a traditional halogen lamp, according to the requirements of FAA "Engineering Brief N°67" document.

2.1.4 Lower Cover

The **lower cover** consists of a treated aluminium casting; it is fastened to the dome by means of three screws HSFH M5x10. An O-Ring is provided between dome and lower cover.

The cover is provided with one or two threaded holes for cable entry and external grounding screw with yellow-green cable lead, size 2.5 mm², 0.250 m long, with male faston terminal. A suitable valve is outside mounted for the leakage test.

Watertightness between fixture and shallow base is ensured by means of a gasket (separately supplied) to be placed on the relevant groove around the lower cover.

The fixture is supplied with one or two **cable lead with L-823 plug**; they consist of two single-pole teflon leads, size 2.1 mm² (#14 AWG), 0.700 m long. The plug is in compliance with FAA AC 150/5345-26 for very quick coupling with the receptacle mounted on the shallow base.

If the light unit is equipped with one cable lead with plug, both the power supply/control board sections will work simultaneously; if it is necessary to operate independently the two power supply/control board sections, then two cable leads with plug are necessary.

The fixture is 203 mm in diameter and 85 mm (+ 18.5 mm for plugs) high; the protrusion above the ground is less than 6.35 mm.

An identification data label is externally applied over the lower cover (Figure 2 – n°2). Moreover, to identify quickly the beam colour, the letters "A" and "B" of the dome in front of the windows are painted in the same colour of the light beam.

Edition 11/03/2014

Supersedes edition 11/29/2013

LED INSET TAXIWAY CENTRELINE, STOP BAR AND INTERMEDIATE HOLDING POSITION LIGHT LTA04
INSTRUCTION MANUAL FOR USE, INSTALLATION AND MAINTENANCE

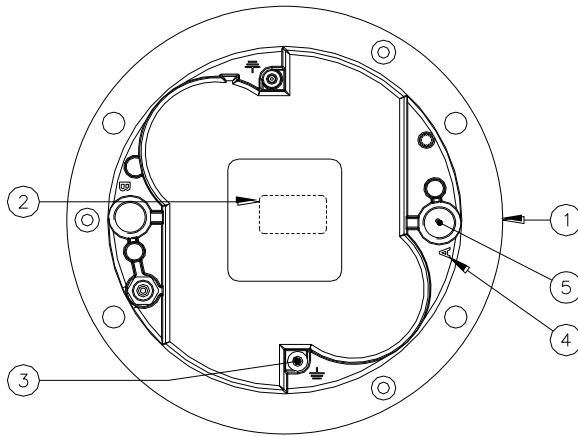

1. Lower cover
2. Identification label
3. Grounding cable hole
4. Letter "A" and "B" for cable lead identification
5. Cable lead entry

Figure 2 – Lower Cover Outside View

The same colour painting is provided outside on the lower cover.
See "Complete P/N identification" figure for P/N information.
All hardware is made of stainless steel.

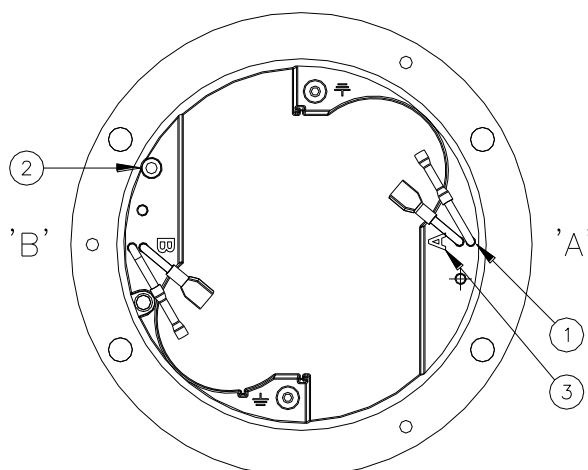

1. Cable lead with plug
2. Leak test valve
3. Letter "A" and "B" for cable lead identification

Figure 3 – Lower Cover Inside View

Edition 11/03/2014

Supersedes edition 11/29/2013

LED INSET TAXIWAY CENTRELINE, STOP BAR AND INTERMEDIATE HOLDING POSITION LIGHT LTA04
INSTRUCTION MANUAL FOR USE, INSTALLATION AND MAINTENANCE

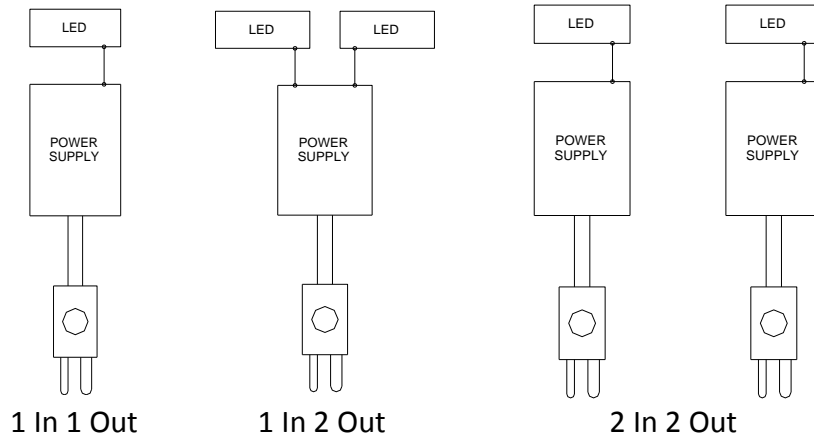

Figure 4 – Wiring Diagram

Edition 11/03/2014

Supersedes edition 11/29/2013

LED INSET TAXIWAY CENTRELINE, STOP BAR AND INTERMEDIATE HOLDING POSITION LIGHT LTA04
INSTRUCTION MANUAL FOR USE, INSTALLATION AND MAINTENANCE

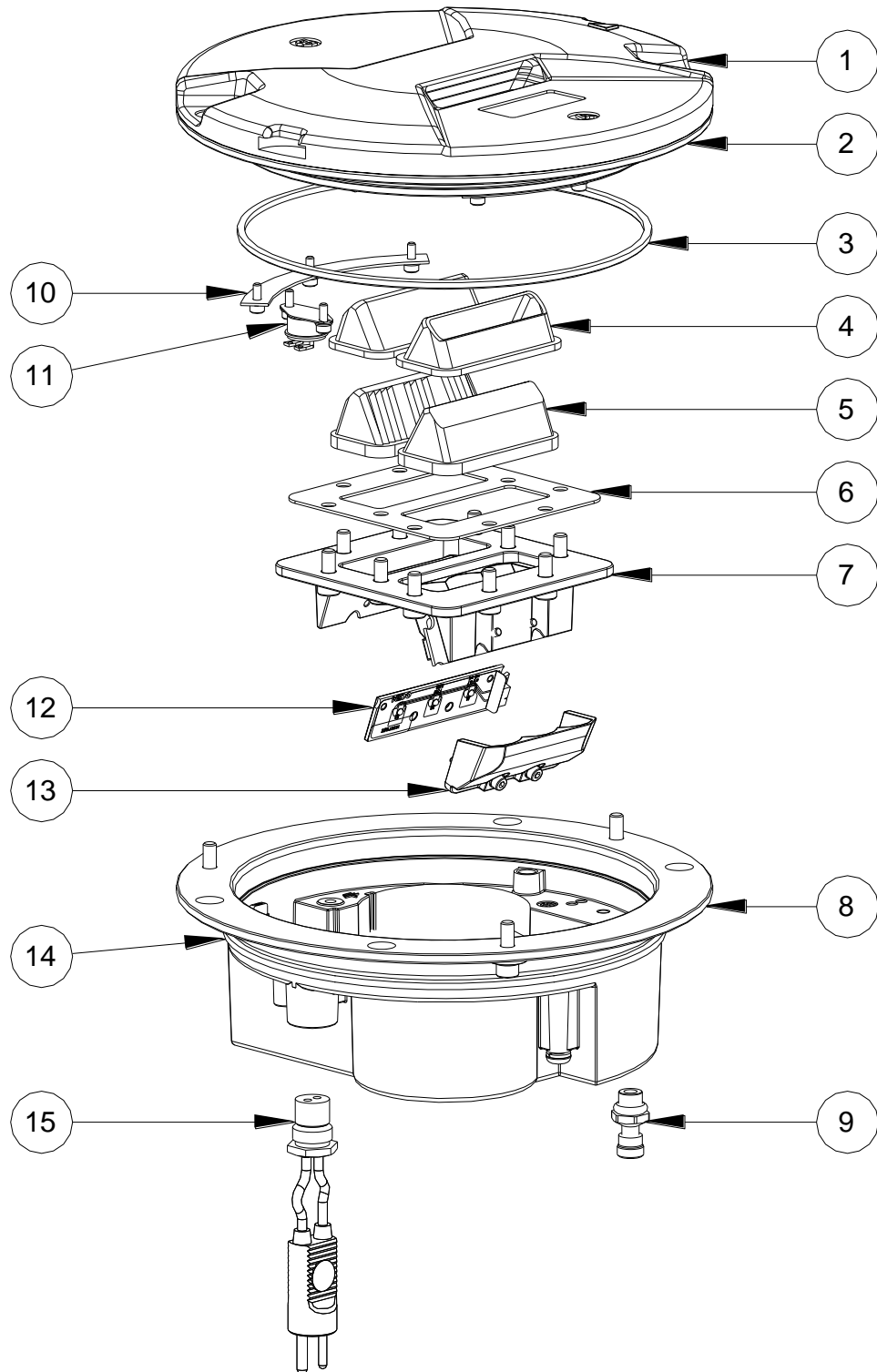

Figure 5 – Exploded View

Edition 11/03/2014

Supersedes edition 11/29/2013

LED INSET TAXIWAY CENTRELINE, STOP BAR AND INTERMEDIATE HOLDING POSITION LIGHT LTA04
INSTRUCTION MANUAL FOR USE, INSTALLATION AND MAINTENANCE

No.	Description	Qty
1	Dome.....	1
2	O-Ring for dome.....	1
3	O-Ring for lower cover.....	1
4	Prism gasket.....	1-2
5	Prism.....	1-2
6	Prism holder gasket.....	1-2
7	Mounting plate.....	1
8	Lower cover with electronic, plug and valve.....	1
9	Valve for watertightness test.....	1
10	Arctic Kit heater.....	1-2
11	Arctic Kit thermostat.....	1-2
12	LED module with accessories.....	1-2
13	Reflector with hardware.....	1-2
14	Lower cover gasket.....	1
15	FAA L-823 plug.....	1-2

Figure 6 – Part List

Edition 11/03/2014

Supersedes edition 11/29/2013

LED INSET TAXIWAY CENTRELINE, STOP BAR AND INTERMEDIATE HOLDING POSITION LIGHT LTA04
INSTRUCTION MANUAL FOR USE, INSTALLATION AND MAINTENANCE

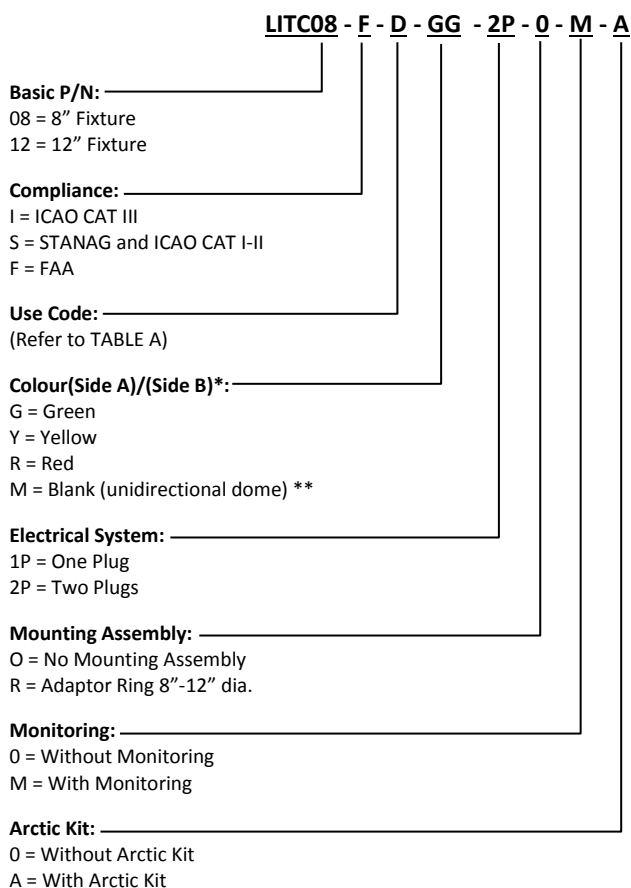

* For curved sections it's necessary to specify the colour of each side, "A" and "B", due to the fixture toe-in

** The not-finished "M" side, on straight sections, is always side "B"

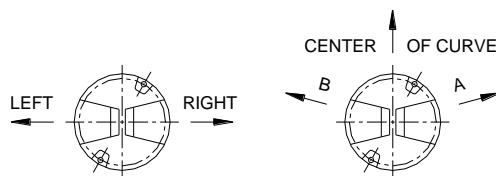

Straight and Curved Section Orientation

Figure 7 - Complete P/N identification

Use	I = ICAO CAT. III	S = ICAO CAT. I - II	F = FAA
A	Fig. A2-12 straight before and after curves	Fig. A2-15 straight	L-852A
B			L-852B
C	Fig. A2-13 straight		L-852C
D			L-852D
W	Fig. A2-14 curved	Fig. A2-16 curved	
K			L-852K
J			L-852J

Table 1 - Use and compliance

2.2 SHALLOW BASE

The **shallow base** (Figure 9) consists of a treated aluminium casting containing an electrical feed-thru system to connect the power cables, consisting of one or two cable leads with receptacle incoming inside the base through one or two cable glands. The cable lead with receptacle consists of two single-pole leads, size 2.5 mm², 1.00 m long, with FAA L-823 receptacle.

The letters "A" and "B" are printed inside the base for cable leads identification.

The base is equipped with an internal grounding screw with yellow-green cable lead, size 2.5 mm², 0.250 m long, with female faston terminal for quick connection to the corresponding of the fixture. An additional external grounding screw is provided close to the cable entry.

The shallow base is designed for cementing in place by means of epoxy-resin in a hole drilled in the pavement.

The fixture has to be fastened to the base by means of two or six M10x30 stainless steel hex cap screws (8" or 12" shallow base resp.). If the base has American threaded holes, UNC 3/8-16 screws can be used. Each locking screw is complete with special sealed external silicon-coated lock-washer.

A gasket (separately supplied) must be placed between base and fixture for watertightness: for 8" fixtures (Figure 8 - n°1) around the lower cover, for 12" fixtures (Figure 9 - n°9) placed in the relevant shallow base groove.

The 12" shallow base is 320 mm in diameter and 150 mm high, while the 8" one is 214 mm in diameter and 125 mm high.

On request, special bases without cable leads can be supplied, provided with holes suitable for conduit connections.

Inside the base two suitable holders (Figure 9 - n°7) are provided to properly sustain the secondary power cable, in case of this cable is inside incoming through a conduit.

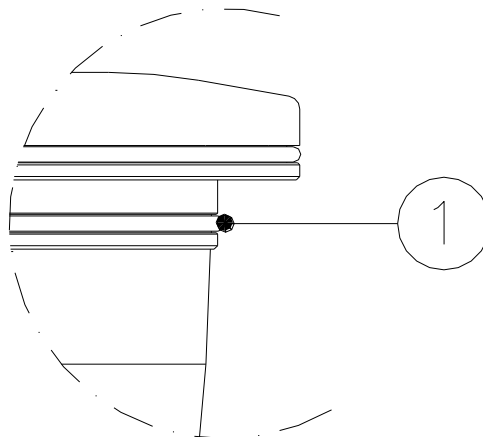

Figure 8 – Gasket of 8" fixture for 8" shallow base

LED INSET TAXIWAY CENTRELINE, STOP BAR AND INTERMEDIATE HOLDING POSITION LIGHT LTA04
INSTRUCTION MANUAL FOR USE, INSTALLATION AND MAINTENANCE

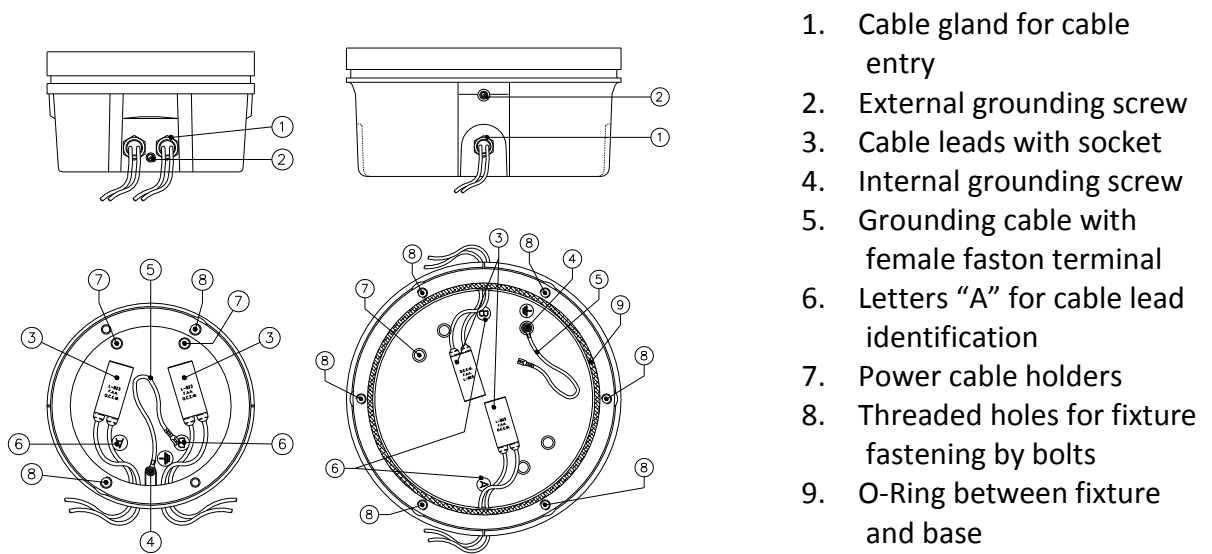

Figure 9 – Standard 8"-12" shallow base

2.3 ELECTRONIC SECTION

The electronic section consists of the following circuits:

- Current / current conversion circuit
- LED command circuit
- Control circuit

2.3.1 Current / current conversion circuit (patented)

This electronic section provide a conversion from the input current value (within range from 2.8 A to 6.6 A) to the specified LED current value.

This conversion, performed in one transformation only, allows to achieve several benefits:

- minimize the power losses
- significant increase of efficiency
- high input power factor
- independent form the CCR topology: the CCR may have any output current waveform
- no percentage of load dependent: the CCR can feed without any problem also few lights in the series circuit
- isolation transformers of smaller size can be used, respect to those used with the equivalent fixtures equipped with halogen lamps

Edition 11/03/2014

Supersedes edition 11/29/2013

LED INSET TAXIWAY CENTRELINE, STOP BAR AND INTERMEDIATE HOLDING POSITION LIGHT LTA04
INSTRUCTION MANUAL FOR USE, INSTALLATION AND MAINTENANCE

To meet the previous features, the conversion circuit is based on the MOSFET technology. This circuit has been designed to withstand the several field stresses (like withstand at elevated current peak) determinate by:

- defective connections along the series circuit
- sudden variations of the CCR power supply voltage; in many cases the CCRs don't provide suitable response time in order to compensate these variations
- use of circuit selectors

The input circuit is protected against over-voltage, tested in accordance with the requirements in FAA "Engineering Brief N°67" document.

2.3.2 LED command circuit

A PWM technique is used to command the LEDs. As known LEDs need to be supplied with a constant current; therefore in order to vary the luminous emission with a proper linearity is necessary the supply current will be applied at impulses. In other words, the LED luminous output depends on the time of application (duty-cycle) of constant current impulses.

2.3.3 Control circuit

The main task of the control circuit is to assure the correct LED light emission according to the series circuit current.

To perform this features, the circuit is provided with a current sensor that generate a signal proportional to the series circuit current.

This signal is analyzed by a DSP which perform a RMS conversion of the input current.

The RMS conversion give a good accuracy with any input current waveform.

Other functions:

- diagnostic, auxiliary voltage control and LED status control. In case of any LED failure or relative power supply circuit failure, the electronic control circuit commands the intervention of the monitoring device so that the secondary side of the isolation transformer becomes open, like in the case of an incandescent lamp failure. This features is essential when the monitoring option is required
- events recording (not-volatile memory) for diagnostic purposes
- PC operator interface through serial connection: this features allows to calibrate the brightness depending on the current, to modify the emission curve, to read the events occurred during the operating time

2.4 ARCTIC KIT

The optional arctic kit is in compliance with FAA "Engineering Brief N°67" document and it prevents from the ice over the prisms area.

LED INSET TAXIWAY CENTRELINE, STOP BAR AND INTERMEDIATE HOLDING POSITION LIGHT LTA04
INSTRUCTION MANUAL FOR USE, INSTALLATION AND MAINTENANCE

The arctic kit is connected in series to the PCB and it consists of a thermostat (two in case of fixture with double cable lead) and one or two heaters. It starts when the dome temperature is less than about -1°C and turns-off when the dome temperature reaches about 10°C .

Arctic kit consumption is less than 20 VA and 40 VA per plug, for 8" and 12" fixtures respectively.

3 INSTALLATION

3.1 PAVEMENT BORING AND SAWCUTTING

Drill each recess in pavement following the instruction in Figure 10.

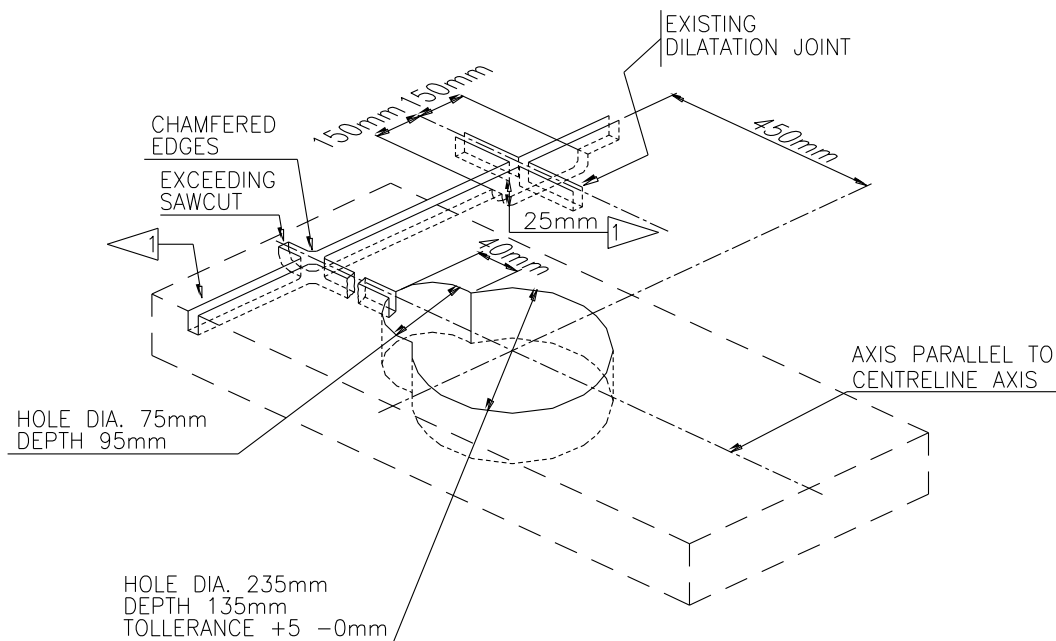

NOTE:

- 1 12" SHALLOW BASE :
- BASE HOLE : DIA: 340mm - 160 mm DEEP (+5 ; -0)
- CABLE GLAND HOLE : DIA: 75mm - 120 mm DEEP

Figure 10 – Pavement Boring, Sawcutting and Joint Intersection Details

Make sure the recess size and depth are maintained within the specified limits. All surfaces of the recess must be clean and dry. If any of these surfaces is damp, it is desirable that it be dried and blown clean with a compressed air blast. The recess side walls must be perpendicular to the pavement surface. The bottom surface must be flat or slightly concave to assure that the shallow base rest securely and in true position. The recess can best be drilled using a diamond-faced core drill in a sturdy, stable drill rig.

Edition 11/03/2014

Supersedes edition 11/29/2013

LED INSET TAXIWAY CENTRELINE, STOP BAR AND INTERMEDIATE HOLDING POSITION LIGHT LTA04
INSTRUCTION MANUAL FOR USE, INSTALLATION AND MAINTENANCE

Mark on the pavement surface the aiming direction of the light by chalk, nails or other devices.

3.1.1 Scheme of Light Configurations

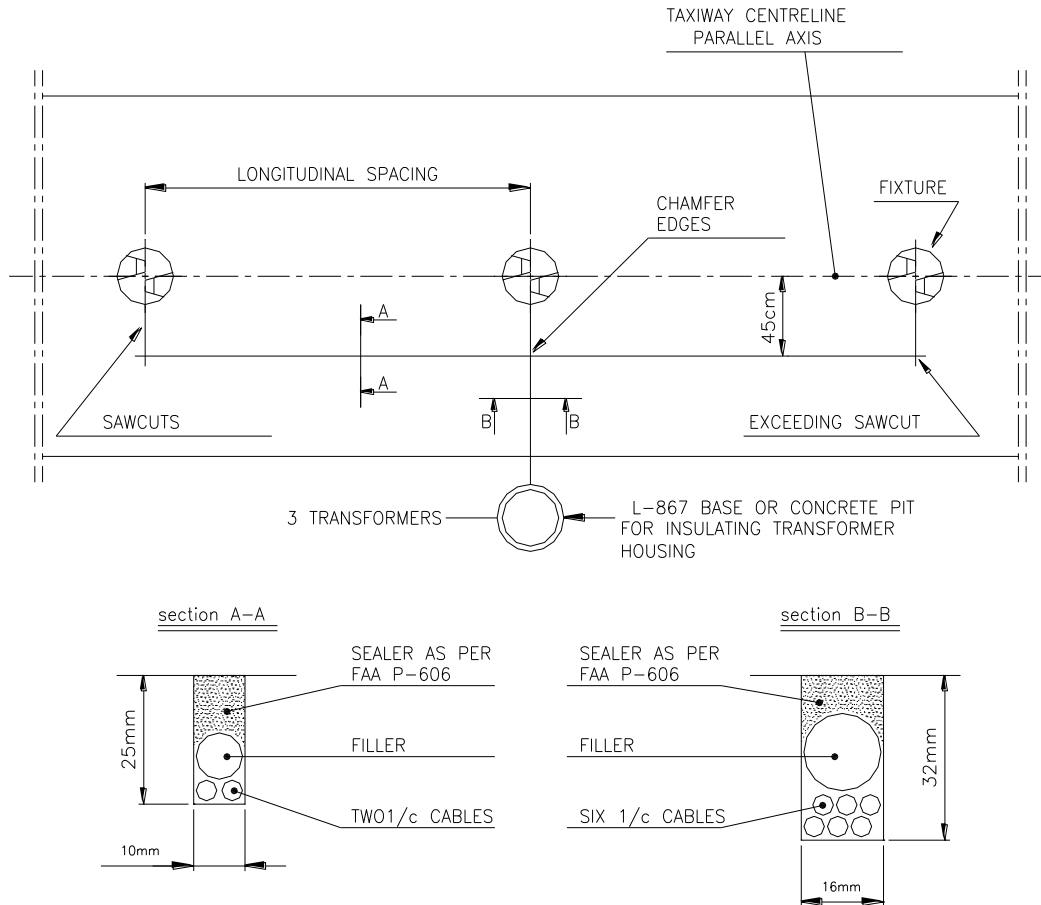

Figure 11 – Taxiway Centreline (ICAO) Scheme of Light Configurations

Edition 11/03/2014

Supersedes edition 11/29/2013

LED INSET TAXIWAY CENTRELINE, STOP BAR AND INTERMEDIATE HOLDING POSITION LIGHT LTA04
INSTRUCTION MANUAL FOR USE, INSTALLATION AND MAINTENANCE

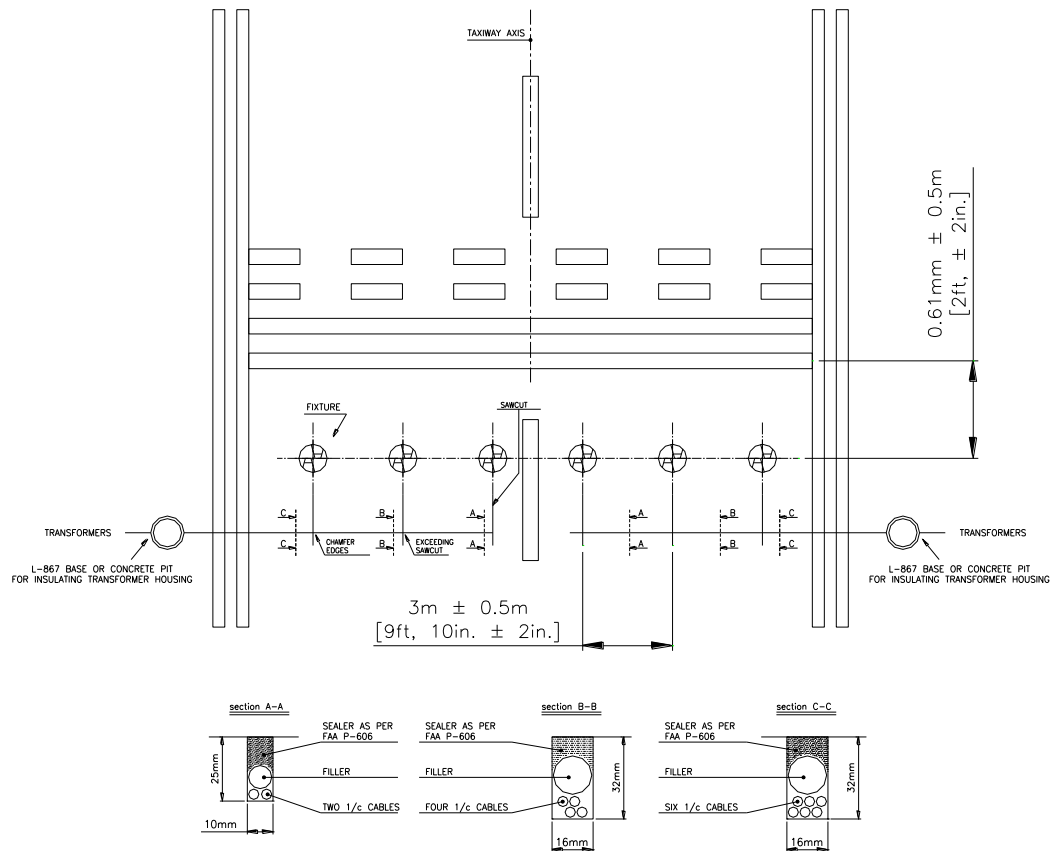

Figure 12 – Stop Bar (ICAO) Scheme of Light Configurations

3.2 CURVED SECTION LIGHT ALIGNMENT

1. Using the scheme in Figure 13 determine the radius (R) of the curve and mark the taxiway radius centre (C').
2. Determine longitudinal spacing (S) between lights. Table 2 is taken from FAA AC 150/5340-30 normative, Table 3 from ICAO Annex 14 – Volume 1.
3. Locate and mark the location of each light (C) on the taxiway section centreline.
4. Mark on the taxiway surface a narrow line (at least 0.90 m or 3 units long) from the light location towards the taxiway radius centre and mark the 0.90 m point (or 3 units) (C'').
5. Using a string or other measuring device, mark an arc of 1.5 m radius (or 5 units) from this last point (C'') on either side of the light.
6. Mark two arcs of 1.2 m radius (or 4 units) from the centre of the light location (C) so as to intersect the first arc, and form a "X" in two places (X' - X'').
7. Draw a straight line between these intersection points (X' - X''): this is a line tangent to the taxiway centreline and can be used to align the taxiway light during positioning.

Edition 11/03/2014

Supersedes edition 11/29/2013

LED INSET TAXIWAY CENTRELINE, STOP BAR AND INTERMEDIATE HOLDING POSITION LIGHT LTA04
INSTRUCTION MANUAL FOR USE, INSTALLATION AND MAINTENANCE

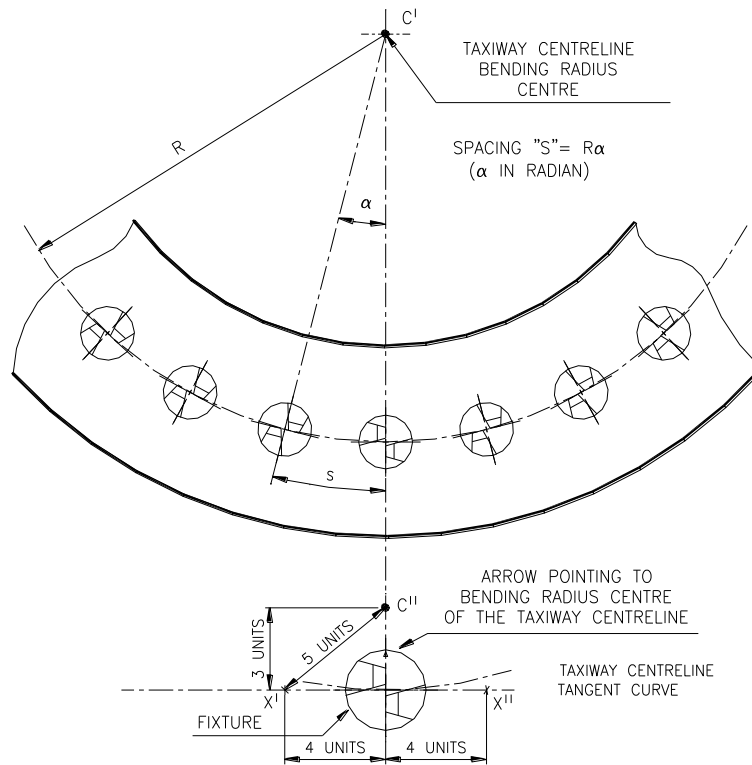

Figure 13 – Curved section light alignment

CURVE RADIUS (R)	LIGHT LONGITUDINAL SPACING (S) - FAA	
	365m RVR and above	Below 365 m RVR
From 23 m to 121 m	7 m	4 m
From 122 m to 364 m	15 m	7 m
364 m or greater	30 m	15 m

Table 2 - Taxiway centreline longitudinal spacing according to FAA

CURVE RADIUS (R)	LIGHT LONGITUDINAL SPACING (S) - ICAO	
	350m RVR and above	Below 350m RVR
Up to 400 m	7.5 m	7.5 m
From 401 m to 899 m	15 m	7.5 m
900 m or greater	30 m	15 m

Table 3 - Taxiway centreline longitudinal spacing according to ICAO

Edition 11/03/2014

Supersedes edition 11/29/2013

LED INSET TAXIWAY CENTRELINE, STOP BAR AND INTERMEDIATE HOLDING POSITION LIGHT LTA04
INSTRUCTION MANUAL FOR USE, INSTALLATION AND MAINTENANCE

3.3 INSTALLING THE SHALLOW BASE

Two different installations are possible:

- Method “A” – cable leads to be laid in wireways
- ▣ Method “B” – cable leads to be laid in cable ducts (Figure 17)

Proceed as follow to realize a proper installation.

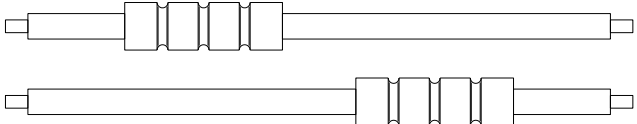
STEP	A	B	ACTIVITY DESCRIPTION
1	•	▣	Take the base from the shipping box.
2	•	▣	To assure an adequate bond between base and hole all external surfaces of the base should be sandblasted and must be cleaned with solvent. TAKE CARE NOT TO DAMAGE THE ELECTRICAL SYSTEM.
3	•	/	Connect an insulated G/Y grounding wire of suitable length to the grounding screw externally provided on the wall of the base.
4	•	/	<p>Splice the light base leads to the power cables using solderless squeeze connectors, as shown in the figure, crimped with the proper tool. Connect also the grounding wire to the main grounding network by using a suitable clamping lug.</p>  <p>ATTENTION: Insulate each splice carefully using either heat shrinkable insulating tubing properly applied or at least three layers of plastic electrical insulating tape applied with half overlap.</p>
5	•	▣	<u>Mount the positioning jig (P/N 332.4301) on the base as shown in Figure 18.</u> An optical device for proper fixture orientation is available (P/N 332.4351 Figure 19).
6	•	/	Properly arrange the leads in the wireways using small pieces of insulating tape if necessary.
7	•	▣	Completely cover the bottom of the base with sealer material, apply a thin coat of sealer to the bottom of the drilled hole to assure a bond between the bottom of the light base and the drilled hole. It may be necessary to place temporary plugs so as to block the wireways entrances into the drilled hole

LED INSET TAXIWAY CENTRELINE, STOP BAR AND INTERMEDIATE HOLDING POSITION LIGHT LTA04
INSTRUCTION MANUAL FOR USE, INSTALLATION AND MAINTENANCE

STEP	A	B	ACTIVITY DESCRIPTION
			<p>(METHOD "A") or the cable ducts entrance (METHOD "B"). The plugs will retain the sealer while it begins to dry up.</p> <p>ATTENTION: avoid starting the installation when the ambient temperature is below 10°C (86°F), unless the sealer used is designed to dry up at a lower temperature.</p>
8	•	▣	<p>Push the base into the recess until its upper side is at the level of the pavement surface; take care no sealer flowing inside the base. Align the notch of the base with the markings on the pavement surface.</p>
9	•	/	<p>Observing the circular level fixed on the jig, level the jig by operating the three leveling lobe knobs (Figure 18). If necessary, a weight may be placed on the jig to hold the light base in position.</p> <p>The remainder of the space between the sides of the shallow base and the drilled hole should be filled with sealer up to approx 25 mm from the pavement, according to the local needs.</p> <p>Fill the remaining 25 mm with a suitable joint sealing filler.</p>
10	/	▣	<p>Observing the circular level fixed on the jig, level the jig by operating the three leveling lobe knobs (Figure 18). If necessary, a weight may be placed on the jig to hold the light base in position.</p> <p><i>When the shallow base is in its final position, the conduit(s) must be properly jointed to the hole(s) provided on the shallow base. This(these) provided either on the wall either on the bottom, the number and dimensions according to customer requirements (</i></p> <p>Figure 16 and Figure 17).</p> <p>The remainder of the space between the sides of the shallow base and the drilled hole should be filled with sealer up to approx 25 mm from the pavement, according to the local needs.</p> <p>Fill the remaining 25 mm with a suitable joint sealing filler.</p>
11	/	▣	<p>Lay the secondary power cable, equipped with a suitable two-pole receptacle kit, and the grounding wire inside the cable duct.</p>

LED INSET TAXIWAY CENTRELINE, STOP BAR AND INTERMEDIATE HOLDING POSITION LIGHT LTA04
INSTRUCTION MANUAL FOR USE, INSTALLATION AND MAINTENANCE

STEP	A	B	ACTIVITY DESCRIPTION
12	●	■	<p>To install a 8" fixture place the O-Ring around the dome (Figure 14- n°1) and between fixture and base (Figure 14- n°2), for 8" fixtures with adaptor ring place the O-Ring between fixture and base (Figure 15- n°3).</p> <p>To install a 12" fixture place the O-Ring around the dome (Figure 15- n°1) and between fixture and base (Figure 15- n°3).</p> <p>Connect the plug and the grounding wire of the fixture with the receptacle and the grounding wire of the base; press the fixture by hand onto the base and secure it using the six (12" base) locking screws complete with washer, one drop of screw paste (e.g. Dow Corning Molycote 1000) should be applied to the screws before installation; two screws are used for 8" base, one drop of anaerobic adhesive, medium type (e.g. Loctite 243) should be applied. Tightening torque is 35 Nm.</p> <p>ATTENTION: The fixture is subject to mechanical damage and/or optical misalignment if not properly seated on the base flange.</p>

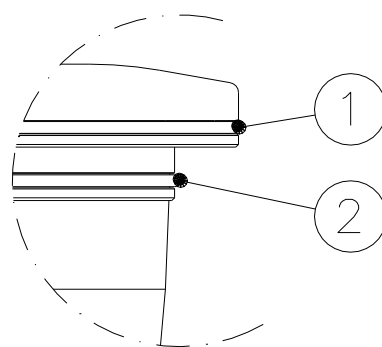

1. O-Ring around the dome
2. O-Ring between fixture and base

Figure 14 – Gaskets for 8" shallow base

Edition 11/03/2014

Supersedes edition 11/29/2013

LED INSET TAXIWAY CENTRELINE, STOP BAR AND INTERMEDIATE HOLDING POSITION LIGHT LTA04
INSTRUCTION MANUAL FOR USE, INSTALLATION AND MAINTENANCE

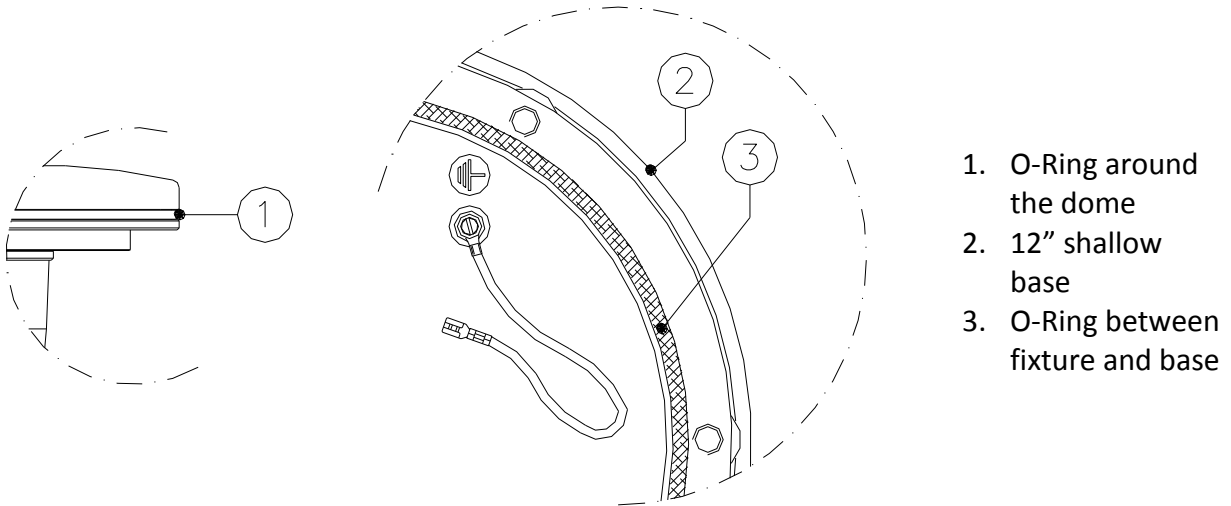

Figure 15 – Gaskets for 12" shallow base

Edition 11/03/2014

Supersedes edition 11/29/2013

LED INSET TAXIWAY CENTRELINE, STOP BAR AND INTERMEDIATE HOLDING POSITION LIGHT LTA04
INSTRUCTION MANUAL FOR USE, INSTALLATION AND MAINTENANCE

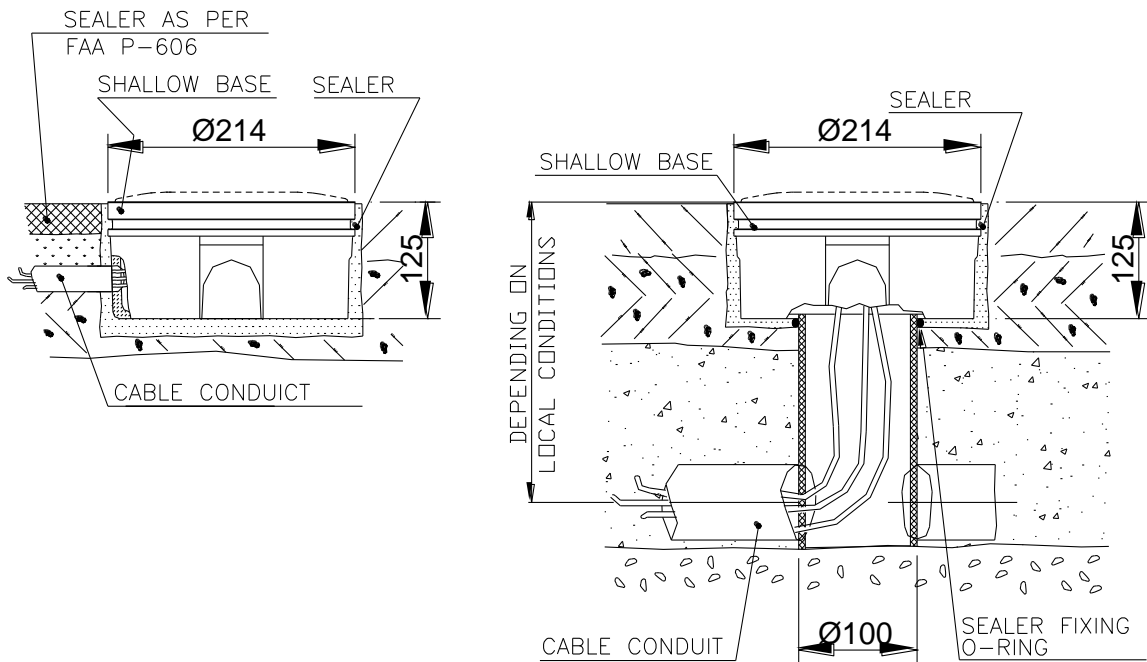

Figure 16 – 8" shallow base for side or bottom ducts (method "B")

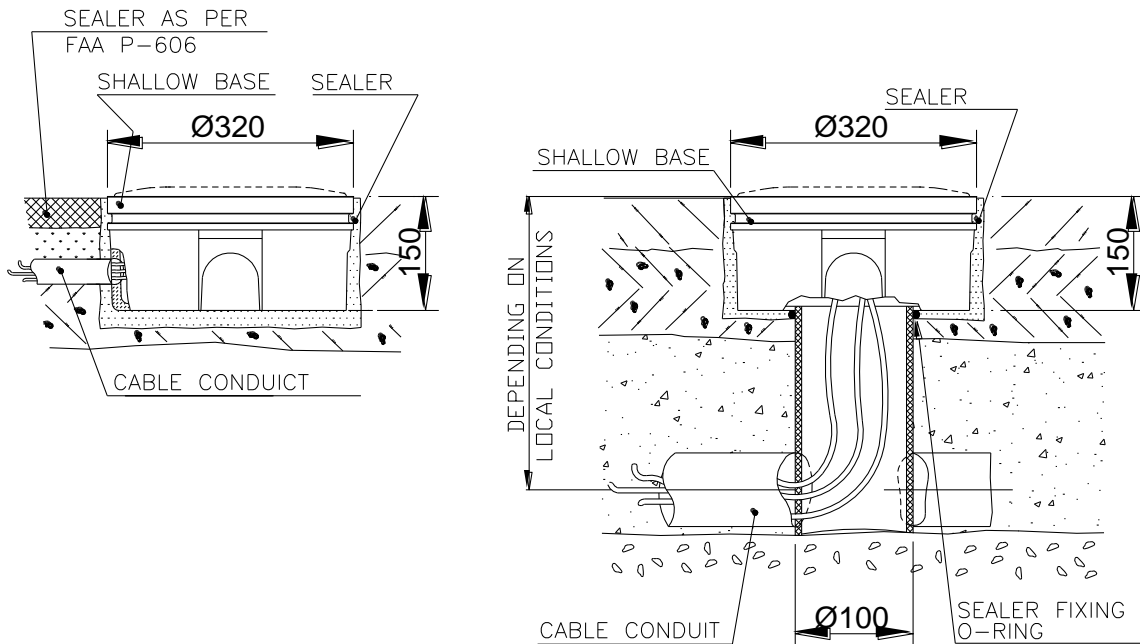
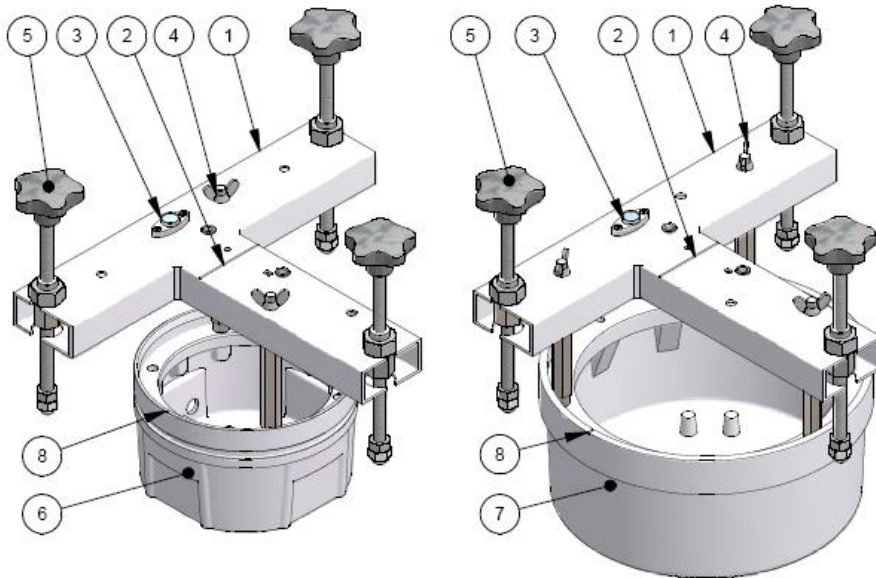

Figure 17 – 12" shallow base for side or bottom ducts (method "B")

Edition 11/03/2014

Supersedes edition 11/29/2013

LED INSET TAXIWAY CENTRELINE, STOP BAR AND INTERMEDIATE HOLDING POSITION LIGHT LTA04
INSTRUCTION MANUAL FOR USE, INSTALLATION AND MAINTENANCE



1. Positioning jig
2. Align the jig notch with the mark on the pavement
3. Circular level
4. Screws and spacers for the jig mounting
5. Lobe knob for positioning jig levelling
6. 8" shallow base
7. 12" shallow base
8. Shallow base notches aligned with the notch on the jig

Figure 18 – Shallow base installation details

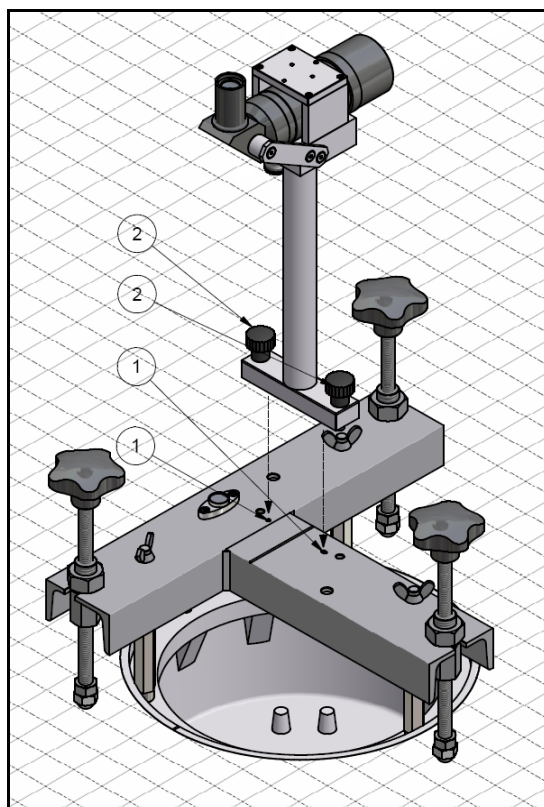

1. Positioning jig holes for optical device reference pins
2. Fixing knobs

Figure 19 – Optical device (refer to the manual UT-MT-0485 for further information)

Edition 11/03/2014

Supersedes edition 11/29/2013

LED INSET TAXIWAY CENTRELINE, STOP BAR AND INTERMEDIATE HOLDING POSITION LIGHT LTA04
INSTRUCTION MANUAL FOR USE, INSTALLATION AND MAINTENANCE

3.4 INSTALLING THE LIGHT UNIT ON L-868 BASE, SIZE B

Install L-868 light base in compliance with FAA AC 150/5340-30.

The fixture is shipped complete (including the lamps) and is ready for installation as received, in case of 8" fixture it shall be complete of adaptor ring.

Be sure the flange on the transformer housing is clean and the O-Ring (Figure 20 – n°2), if used, is in place in the O-Ring groove.

Connect the plug of the fixture to the receptacle of the isolating transformer inside the deep base. Connect the grounding wire of the fixture to the grounding wire of the deep base (faston connection). Then press the fixture firmly and evenly by hand onto the base flange. Secure the fixture to the base by using the six locking screws complete with washers, supplied with the base. One drop of anaerobic adhesive, medium type (e.g. Loctite 243) should be applied to the screws before installation; tightening torque is 25 Nm.

The fixture is subject to optical misalignment and/or mechanical damage if not properly seated.

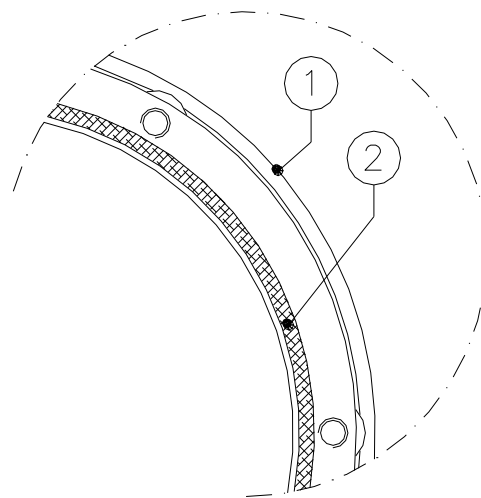

1. L-868 base
2. O-Ring between fixture and base

Figure 20 – Gaskets for L-868 base

3.5 SECONDARY WIRING

The IEC 61823 International Standard (AGL series transformers) states at para. 4.6 that “if an earthing connection is provided, it shall be connected to the larger socket of the transformer secondary connector.”

Edition 11/03/2014

Supersedes edition 11/29/2013

LED INSET TAXIWAY CENTRELINE, STOP BAR AND INTERMEDIATE HOLDING POSITION LIGHT LTA04
INSTRUCTION MANUAL FOR USE, INSTALLATION AND MAINTENANCE

This means that, when a fixture is directly connected to the relevant isolation transformer (provided with earthing connection), the fixture secondary side is wired to the grounding network through the larger pin of fixture plug.

In case of an inset fixture, installed in the taxiway/runway pavement on its shallow base far from the relevant isolation transformer, it is necessary to provide a secondary extension between fixture and transformer. To help the installer to identify the larger socket of the female connector inside the base (when installed), the base secondary cable leads are identified by a colour code: the grey wire is wired to the larger socket, the black wire to the other one. In this way it will be easy to assure the earthing wiring, above described, between the larger socket of the transformer secondary connector and the larger pin of the fixture plug.

4 MAINTENANCE

WARNING
BEFORE ANY MAINTENANCE INTERVENTION, MAKE SURE
THE POWER SUPPLY BE SWITCHED OFF.
DO NOT OPERATE ON LIVE PARTS!!!

LED lighting fixtures do not require frequent maintenance. With well-run installations and handling fixture carefully, avoiding excessive falls or collisions, the only maintenance work to be carried out on the field is to clean the prisms.

4.1 MAINTENANCE PROGRAM

In order to ensure maximum light fixture life, the installed units should be subject to a maintenance program in accordance with the following instructions and taking as reference the Airport Service Manual ICAO - Part 9 - Airport Maintenance Practices or FAA AC 150 5340-30.

4.1.1 Periodical Checks

Weekly	Cleaning of the prisms and the light output channel of runway fixtures
Bi-monthly	Cleaning of the prisms and the light output channel of taxiway fixtures
Annually	Check for burned-out led
	Check for moisture inside the fixture
STABILITY OF THE CIVIL WORKS OF RUNWAY FIXTURES	
Unscheduled	Check for water in base
	ELECTRICAL CONNECTIONS AND INSULATION DEGREE
	LEAKAGE TEST
	Condition of all gaskets
	Check torque of mounting bolts after a month of their first installation
	Remove snow from around fixtures
	Check wires in saw kerfs

Edition 11/03/2014

Supersedes edition 11/29/2013

LED INSET TAXIWAY CENTRELINE, STOP BAR AND INTERMEDIATE HOLDING POSITION LIGHT LTA04
INSTRUCTION MANUAL FOR USE, INSTALLATION AND MAINTENANCE

4.1.2 Snowplow Operations

Snowplow operators should exercise extra care not to strike the light fixtures with snowplow blades. After snow removal operations, inspect all light fixtures to locate and replace, if necessary, any damaged light assemblies.

Passes over the light rows should be made with a power broom only if practical. Whenever snowplows must traverse in-pavement light fixtures, they should be either travelling at less than 10 km/h or have the blades lifted clear of the fixtures. Recommended snow removal techniques are described in Airport Service Manual ICAO - Part 9 - Airport Maintenance Practices or FAA AC 150/5200-30.

REMOVING AND OPENING THE LIGHT UNIT FROM THE BASE

4.1.3 Removing the fixture

- Remove the fixture from the base, after switching off, by unscrewing the two locking screws complete with washers.
- Raise the fixture by using the two lifting tools (P/N 332.4140 or 332.4230) inserted in the suitable slots provided on the dome. As an alternative, two screwdrivers can be used.
- Disconnect the fixture plug/s and grounding cable from those inside the shallow base.

4.1.4 Opening the fixture

- Unscrew the leak valve cap and push the valve central pin, in this way the light internal pressure is the same of the atmospheric pressure.
- Open the fixture by unscrewing the three locking screws HSFH M5x10 (Figure 21 - n°1).

Every time the fixture is opened, inspect the following parts and replace them if necessary:

- prism, if it is dirty or damaged
- prism gasket, check the integrity
- cable lead with plug

4.1.5 Closing the fixture

Every time the fixture is opened **replace** the following items with a new ones:

- three locking screws HSFH M5x10 (Figure 21 - n°1);
- O-Rings between dome and lower cover (Figure 23 – n°2);

Verify the correct position of O-Ring between dome and lower cover (Figure 23 – n°2); mount the lower cover on the dome and fasten it by means the three screws HSFH M5x10 (Figure 21 - n°1). One drop of anaerobic adhesive lower type (e.g. LOXEAL 24-18) should be applied to the screws before installation; tightening torque is 2.5 Nm.

Edition 11/03/2014

Supersedes edition 11/29/2013

LED INSET TAXIWAY CENTRELINE, STOP BAR AND INTERMEDIATE HOLDING POSITION LIGHT LTA04
INSTRUCTION MANUAL FOR USE, INSTALLATION AND MAINTENANCE

Figure 21 - Lower Cover Fixing Screws

4.1.6 Leakage test

The assembly should be given a 1.38 kPa air pressure test. This can be done by connecting an external air pressure line to the valve (Figure 22– n°2) provided on the lower cover. Immerse the assembly under water, so air loss will be easily viewed if some part is damaged or assembling is wrong.

If there is no air loss then test is passed successfully.

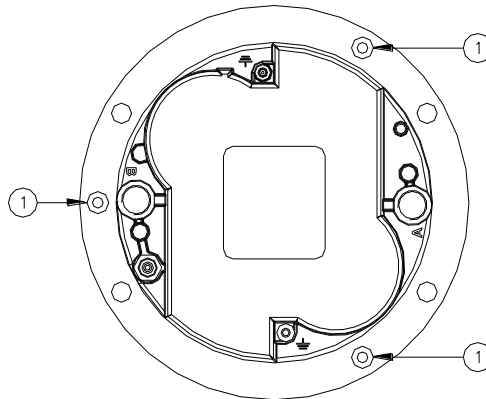
Light unit is ready to be field installed.

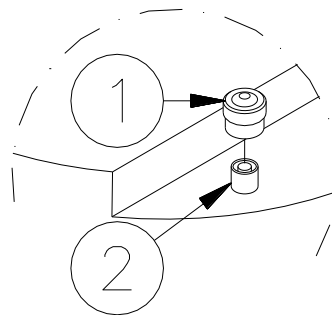

Figure 22 - Lower Cover with Pressure Valve

4.1.7 Reinstalling the fixture

Every time the fixture is removed from the base **replace** the following items with a new ones making sure that are right placed in the relevant groove:

- the two special seal lock washers;
- O-Ring around the dome (Figure 23 – n°3);
- Gasket between fixture and 8" shallow base (Figure 23 – n°4);
- O-Ring between fixture and 12" shallow base (Figure 23 – n°7);
- The fixture is ready to be field installed.

LED INSET TAXIWAY CENTRELINE, STOP BAR AND INTERMEDIATE HOLDING POSITION LIGHT LTA04
INSTRUCTION MANUAL FOR USE, INSTALLATION AND MAINTENANCE

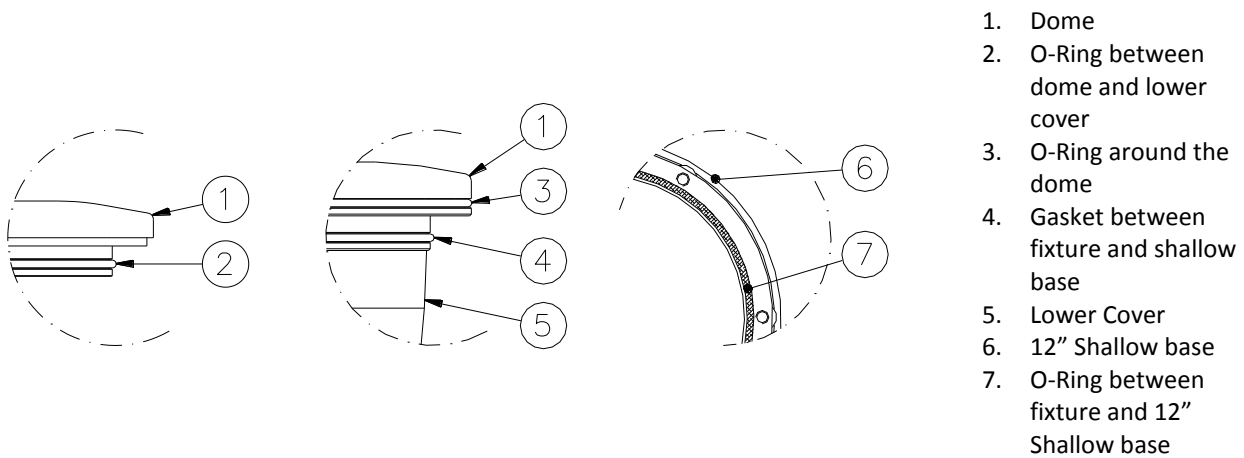

Figure 23 – Fixture Gaskets

4.2 PRIMS CLEANING

4.2.1 Prism outside cleaning

- Removing the fixture is not necessary to clean the outer surface of the prisms, and if already removed is not necessary to open it. Clean the prisms surface with non abrasive glass product.

4.2.2 Prism inside cleaning

Normally the cleaning of the prism inside surfaces is not necessary because fixture is watertight. Whenever it is necessary, remember the following rules.

Remove the fixture from the base and open it following instructions of *“Removing and Opening the Light Unit From the Base”* and proceed as follows:

- remove the mounting plate (Figure 24 - n°3) unscrewing the relevant screws HSCS M5x12 (Figure 24 - n°4)
- remove the prism holder gasket (Figure 24 - n°2)
- clean the prism surface (Figure 24 - n°1) with non abrasive glass product
- dry them carefully
- reassembly the light unit

Close the light fixture following instructions of paragraph *“Closing the Fixture”*, *“Leakage Test”* and *“Reinstalling the fixture”*.

Edition 11/03/2014

Supersedes edition 11/29/2013

LED INSET TAXIWAY CENTRELINE, STOP BAR AND INTERMEDIATE HOLDING POSITION LIGHT LTA04
INSTRUCTION MANUAL FOR USE, INSTALLATION AND MAINTENANCE

Figure 24 – Prism Surface to be Cleaned

4.3 PRISM REPLACEMENT

If the prism is damaged it must be replaced as described below.

It is highly recommended to do a complete overhaul of the fixture. Contact OCEM - ENERGY TECHNOLOGY for any suggestion.

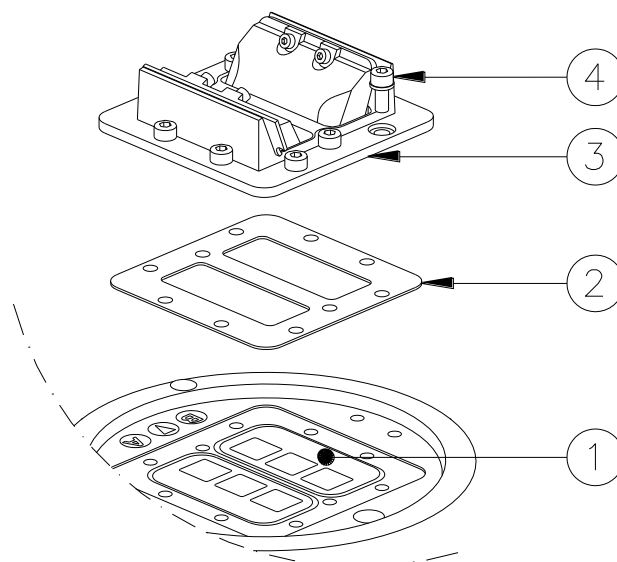
4.3.1 Removing the Prism

Remove the fixture from the base and open it following instructions of “*Removing and Opening the Light Unit From the Base*” and proceed as follows:

- clean out possible pieces of the old prism and all accumulated debris from inside the fixture
- remove the mounting plate and prism holder gasket (Figure 25 – n°4-5)
- remove the old prism and the gasket (Figure 25 – n°3-2)
- carefully clean the prism seat by scraping and taking care not to damage the relevant walls.

Edition 11/03/2014

Supersedes edition 11/29/2013

LED INSET TAXIWAY CENTRELINE, STOP BAR AND INTERMEDIATE HOLDING POSITION LIGHT LTA04
INSTRUCTION MANUAL FOR USE, INSTALLATION AND MAINTENANCE

4.3.2 Installing the New Prism

- place a new gasket (Figure 25 – n°2) in the prism cavity on the dome (Figure 25 – n°1)
- position and press by hand the prism (Figure 25 – n°3) in the relevant seat
- position the prism holder gasket and the mounting plate (Figure 25 – n°4-5) and fasten it with the relevant screws HSCS M5x12 (Figure 25 – n°6) following the numbers marked on the mounting plate, tightening torque is 2.5 Nm
- inspect all components inside the light unit for damages or signs of corrosion and replace it if necessary.

Close the light fixture following instructions of paragraph “Closing the Fixture”, “Leakage Test” and “Reinstalling the fixture”.

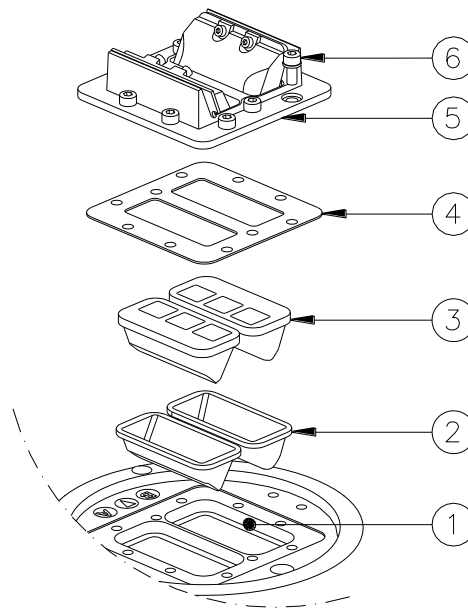

Figure 25 - Prism Replacement

4.4 LED MODULE REPLACEMENT

Remove the fixture from the base and open it following instructions of “Removing and Opening the Light Unit From the Base” and proceed as follow:

- disconnect the power supply connector from the LED module (Figure 26 – n°3)
- remove the LED module (Figure 26 – n°4) and the relevant reflector (Figure 26 – n°1) from the mounting plate unscrewing the two screw HSCS M3x16
- replace the LED module it with a new one

Edition 11/03/2014

Supersedes edition 11/29/2013

LED INSET TAXIWAY CENTRELINE, STOP BAR AND INTERMEDIATE HOLDING POSITION LIGHT LTA04
INSTRUCTION MANUAL FOR USE, INSTALLATION AND MAINTENANCE

- check that the thermal interface (Figure 26 – n°5) is placed under the LED module and right-positioned
- check that the Kapton insulating sheet (Figure 26 – n°2) is placed over the LED board is lying down and right-positioned
- fasten the LED module and the relevant reflector with a tightening torque of 0.6 Nm
- reconnect the power supply connector (Figure 26 – n°3) to the LED module

Reassembly the fixture following instructions of paragraph “Closing the Fixture”, “Leakage Test” and “Reinstalling the fixture”.

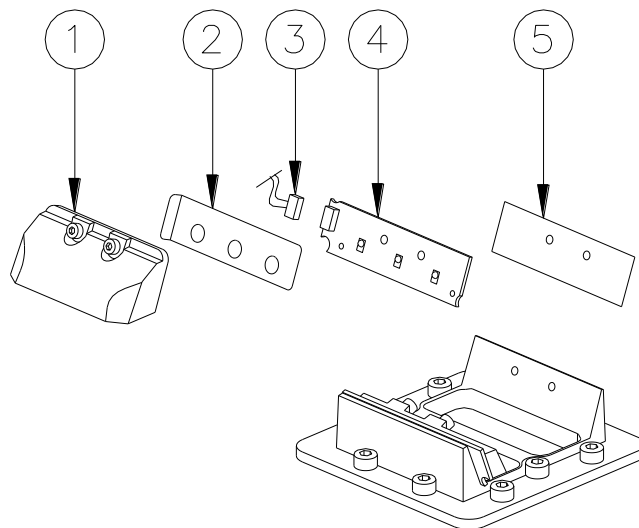

Figure 26 – LED Module Replacement

4.5 ELECTRONICS REPLACEMENT

Remove the fixture from the base and open it following instructions of “Removing and Opening the Light Unit From the Base” and proceed as follow:

- disconnect the power supply connector(s) from the LED module(s)
- replace the entire lower cover with a new one complete with electronic section
- reconnect the power supply connector(s) to the LED module(s)

Reassembly the fixture following instructions of paragraph “Closing the Fixture”, “Leakage Test” and “Reinstalling the fixture”.

Edition 11/03/2014

Supersedes edition 11/29/2013

LED INSET TAXIWAY CENTRELINE, STOP BAR AND INTERMEDIATE HOLDING POSITION LIGHT LTA04
INSTRUCTION MANUAL FOR USE, INSTALLATION AND MAINTENANCE

4.6 ARCTIC KIT REPLACEMENT

4.6.1 Thermostat

Remove the fixture from the base and open it following instructions of *“Removing and Opening the Light Unit From the Base”* and proceed as follow:

- disconnect the thermostat from the cable lead with plug and from the PCB
- unscrew the two screws HSCS M3x8
- unsolder the heater cable from the thermostat
- take a new thermostat and solder the heater cable on the new thermostat terminals
- protect the soldered joint from moisture with a piece of suitable heat shrink tubing
- tighten the two screws with tightening torque 0.6 Nm

4.6.2 Heater

- unsolder the heater cable from the thermostat
- unscrew the three screws HSCS M3x8 which fasten the heater
- solder the new heater cable on the thermostat terminals
- protect the soldered joint from moisture with a piece of suitable heat shrink tubing
- clean the heater dome area
- apply silicon thermal paste (like Wacker P12) under the new heater
- position the heater on the dome and tighten the three screws with plastic washer; tightening torque 0.6 Nm

Reassembly the fixture following instructions of paragraph *“Closing the Fixture”*, *“Leakage Test”* and *“Reinstalling the fixture”*.

Edition 11/03/2014

Supersedes edition 11/29/2013

LED INSET TAXIWAY CENTRELINE, STOP BAR AND INTERMEDIATE HOLDING POSITION LIGHT LTA04
INSTRUCTION MANUAL FOR USE, INSTALLATION AND MAINTENANCE

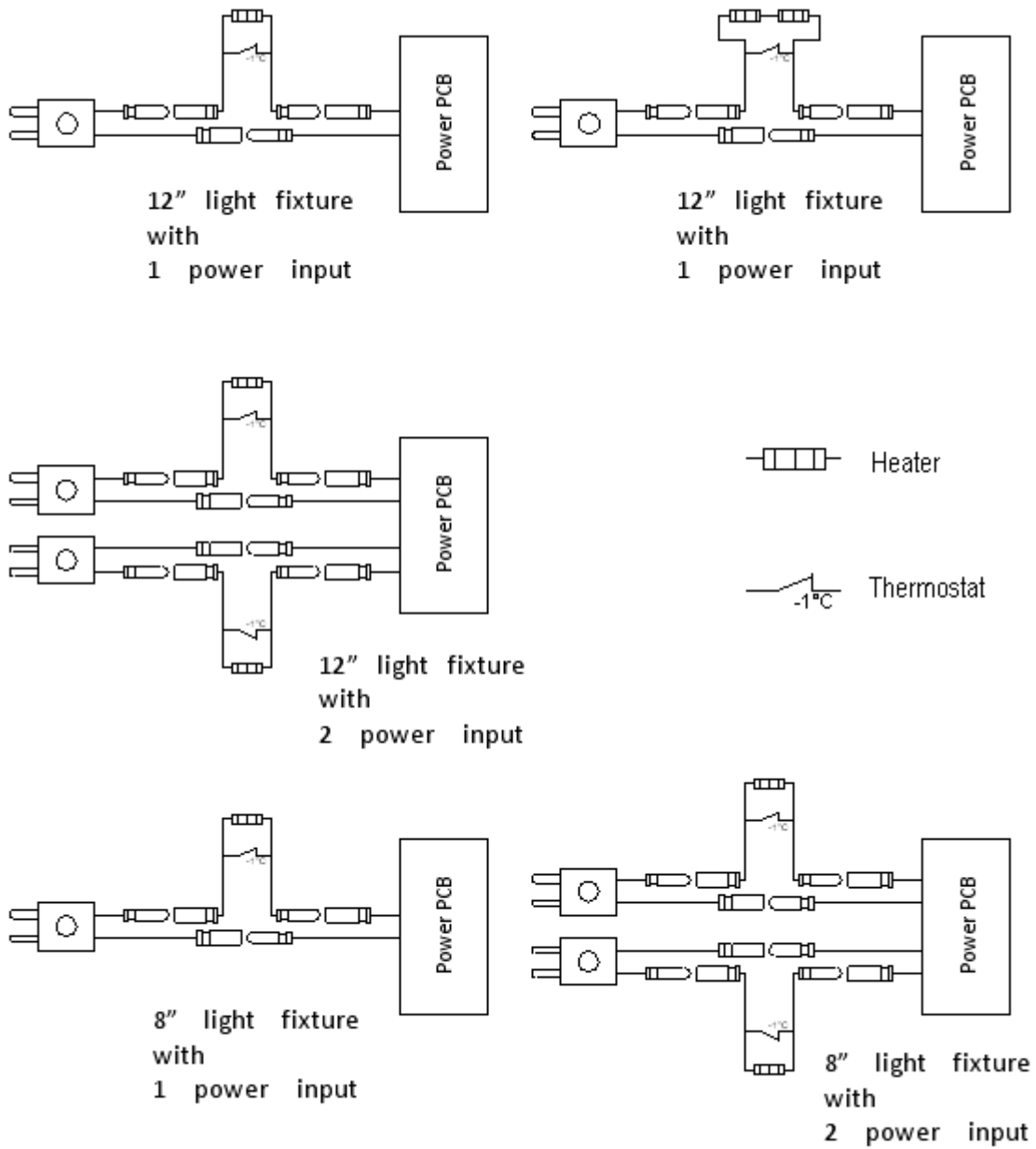

Figure 27 – Wiring diagrams for the heaters

4.7 GASKETS

4.7.1 Gasket examination

Every time a fixture is opened each O-Ring must be examined as described below and **replaced** if necessary.

Any O-Ring that is stretched, torn, has a permanent set or some other defect, which would prevent it from obtaining a water-tight seal **must be replaced with a new O-Ring**.

LED INSET TAXIWAY CENTRELINE, STOP BAR AND INTERMEDIATE HOLDING POSITION LIGHT LTA04
INSTRUCTION MANUAL FOR USE, INSTALLATION AND MAINTENANCE

Remove the fixture from the base and open it following instructions of *“Removing and Opening the Light Unit From the Base”*.

Light assembly is equipped with the following gaskets:

- O-Ring between dome and lower cover (Figure 28 - n°2);
- O-Ring around the dome (Figure 28 - n°3);
- Gasket between fixture and 8” shallow base (Figure 28 - n°4);
- O-Ring between fixture and 12” shallow base (Figure 28 - n°7);
- prism gasket mounted between prism and dome (Figure 29- n°2).

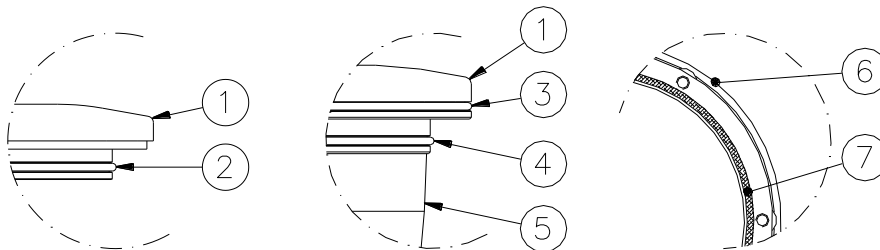

1. Dome
2. O-Ring between dome and lower cover
3. O-Ring around the dome
4. Gasket between fixture and shallow base
5. Lower Cover
6. 12" Shallow base
7. O-Ring between fixture and 12" Shallow base

Figure 28– Fixture Gaskets

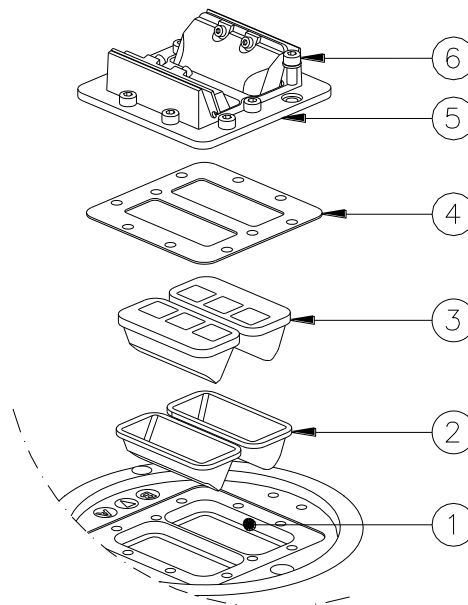

Figure 29 – Prism Gasket

Edition 11/03/2014

Supersedes edition 11/29/2013

 LED INSET TAXIWAY CENTRELINE, STOP BAR AND INTERMEDIATE HOLDING POSITION LIGHT LTA04
 INSTRUCTION MANUAL FOR USE, INSTALLATION AND MAINTENANCE

4.7.2 O-Ring replacement

Remove the old O-Ring from the groove and clean the flange mating surfaces and the groove, scraping carefully. Take care not to damage the mating surface and the bottom and sides of the groove. Position it in the centre of its groove and push it inside.

NOTE 1: Make sure that the proper O-Ring is re-inserted into the groove.

NOTE 2: The seat of an O-Ring gasket is dimensioned to allow the proper positioning when compressed between the mating surfaces. Screws properly tightened are important in obtaining a complete seal.

TIGHTENING TORQUE	
lower cover HSCS M5x10	2.5 Nm
fixture locking screw	35 Nm (for shallow base) 25 Nm (for L-868 base, size B)

4.8 CABLE LEAD WITH PLUG

4.8.1 Removing the cable lead with plug

Remove the fixture from the base and open it following instructions of *“Removing and Opening the Light Unit From the Base”*.

Inside the lower cover, disconnect the pair of wires from the electronics by cutting the cables, unscrew the gland and pull out the cable lead with gland gasket.

4.8.2 Installing the new cable lead with plug

Insert on the new power supply cable lead with plug (

Figure 30 – n° 1) the new gland nut (

Figure 30 – n° 2) with teflon washer (

Figure 30 – n° 3), metal washer (

Figure 30 – n° 4) and then the new gland gasket (

Figure 30 – n° 5) so that the available length of cables outside the fixture is approx. 50 cm when re-assembled. Pull both cables through the suitable hole provided in the bottom of the lower cover; then splice each cable for a length of approx. 7 mm and clamp the female faston terminal to the cable (

Figure 30 – n° 6) and the male ones to the electronics wires.

Place the gland gasket inside its seat and tighten the gland nut. Restore internally the electrical connections.

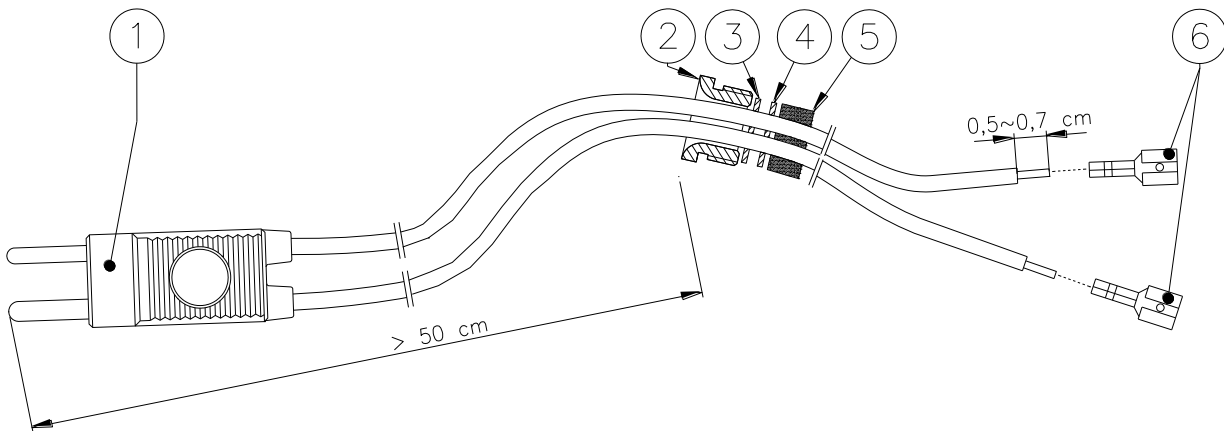

Figure 30 - Cable Lead With Plug

Close the light fixture following instructions of paragraph “Closing the Fixture”, “Leakage Test” and “Reinstalling the fixture”.

4.9 PRESSURE VALVE

If a leakage is found through the pressure valve during an air pressure test, check carefully where the leakage happens. If the leakage is between the valve (Figure 31 - n°2) and the lower cover (Figure 31 - n°1), check the tightening of the valve body to the lower cover from the outside of the fixture.

In case the pressure valve needs replacing operate as follows, considering the fixture already opened following instructions of “Removing and Opening the Light Unit From the Base”. Unscrew the valve body with gasket from the outside of the lower cover (Figure 31 - n°1) by clamping the hexagonal end section of the valve body. Screw the new valve on the lower cover; tightening torque is 0.35 Nm. Check the valve core (Figure 31 - °4) is tightened to the valve body (Figure 31 - n°2) and then screw its cap (Figure 31 - n°3).

Reassembly the light unit following instructions of paragraph “Closing the Fixture”, “Leakage Test” and “Reinstalling the fixture”.

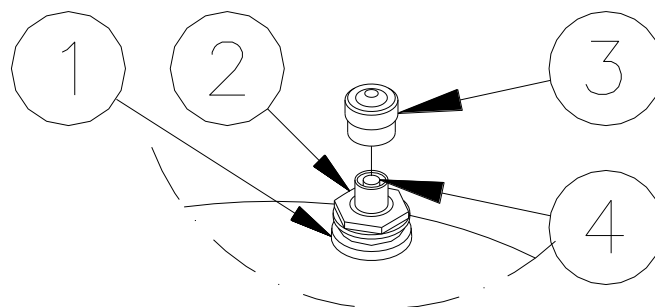

Figure 31 - Lower Cover with Pressure Valve

Edition 11/03/2014

Supersedes edition 11/29/2013

LED INSET TAXIWAY CENTRELINE, STOP BAR AND INTERMEDIATE HOLDING POSITION LIGHT LTA04
INSTRUCTION MANUAL FOR USE, INSTALLATION AND MAINTENANCE

4.10 CLEANING

Service life depends upon the entire assembly being waterproof. All surfaces must be clean, dry and free of all foreign matter if the light fixture is to operate for an extended period without requiring maintenance.

4.11 MONITORING

The fixtures can be provided with the option of monitoring. This device allows to show at the constant current regulator as if the fixture circuit was open when a LED burns out. The fixture thus acts as a traditional lamp fixture.

When the fixture has a bad operation, the internal monitoring device disconnects definitively the fixture from the series circuit; after this operation to restore the normal operation of the fixture it's necessary to replace the LED board and unlock the monitoring device. For this operation it is necessary to follow these steps:

- remove the fixture from the base and open it following instructions of *“Removing and Opening the Light Unit From the Base”*
- replace the LED module following instructions of *“LED Module Replacement”*
- restore the condition of proper functioning of the monitoring device as shown in Figure 32

Reassembly the fixture following instructions of paragraph *“Closing the Fixture”*, *“Leakage Test”* and *“Reinstalling the fixture”*.

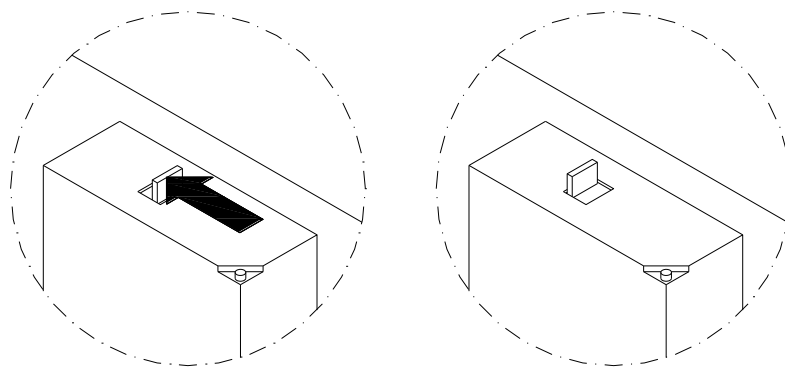

Figure 32 - Restoring the Monitoring Device

Edition 11/03/2014

Supersedes edition 11/29/2013

LED INSET TAXIWAY CENTRELINE, STOP BAR AND INTERMEDIATE HOLDING POSITION LIGHT LTA04
INSTRUCTION MANUAL FOR USE, INSTALLATION AND MAINTENANCE

5 TROUBLESHOOTING

Problem	Possible cause	Solution
Distorted light beam output	Broken or damaged prism	Replace prism
	Wrong prism installed	CHECK PARTS LIST AND INSTALL THE CORRECT PRISM
Weak light output	Primary loop with partial short circuit	Check cable assembly
	Defect in the isolation transformer	Replace transformer
	Dirty prism or dome	Clean the light fixture
	One LED of the luminous source damaged in short circuit (only without the monitoring option)	Replace the LEDs board
	Wrong power PCB installed	Check parts list and install the correct PCB
Luminous source not working	LEDS DEFECTIVE	Replace the LEDs board
	POWER PCB DEFECTIVE	Replace the Power PCB
	Moisture inside the fixture	Execute leakage test and replace damaged components. Clean and dry the inside area of the fixture
	No connection of primary circuit	Check transformer output current with A-meter
	Defective isolation transformer or secondary wiring	Check power line between the light fixture and the transformer, including connectors
	Monitoring device locked (only if this option)	Unlocked monitoring device
Water or moisture inside the fixture	Prism gasket, O-rings between dome and lower cover	Replace all gasket and execute leakage test
	Pinched fixture power cables	Replace fixture leads