

LERE



LED ELEVATED RUNWAY EDGE AND THRESHOLD/END LIGHT

COMPLIANCES

ICAO: Annex 14 - Volume I Fig. A2-3, A2-8, A2-9, A2-10

FAA: L-862-E(L) AC150/5345-46 and EB No.67

IEC: TS 61827

NATO: STANAG 3316

CAA: CAP 168

TCCA: TP312

EASA: CS-ADR-DSN, Book 1, fig.U-13, U-14, U-7, U-12

CASA: Manual of Standard Part 139

APPLICATIONS

Runway edge and threshold/end for ICAO CAT I, II and III, FAA and military runways

BENEFITS

- 60000 hours LED rated life at full intensity, but over 100000 hours in field operating conditions
- In new installation, LED lights mean lower loads, lower size of CCRs and transformers, thus low life cycle costs
- The light output is variable like a traditional halogen lamp, as indicated by the FAA "Engineering Briefing No.67"
- Colour emitted directly by LEDs: absence of coloured filters ensures no energy losses and no colour shifts
- Fully compatible with existing AFL infrastructure*
- Designed with simplicity allowing longer maintenance intervals and fewer spare parts
- Customized gasket for glass cover to avoid the use of sealing
- No optical adjustment after LED module or lens array replacement
- Operating with any topology of CCRs designed in compliance with IEC or FAA requirements

* For monitored fixtures, isolation transformer max size: 150VA

PERFORMANCES

- The electronic is strong-built and highly resistant to shock and vibration
- Automatic adaptation to the frequency of the supply current
- A surge protection device is provided in the electronics as required by the FAA "Engineering Briefing No.67"
- Immediate detection of an internal fault
- Lightweight and sturdy due to aluminium die-castings
- Powder coating surface finishing to provide good corrosion resistance
- Body balanced on the slipfitter for proper levelling by means of four external screws
- High jet blast resistance due to the small size of the fixture, 320 mm high
- Protection degree: IP67
- Temperature range: -55°C to +55°C

INSTALLATION

- The fixture can be installed on pipe elbow or baseplate
- Specific tools available for easy and precise installation

PHOTOMETRIC PERFORMANCES

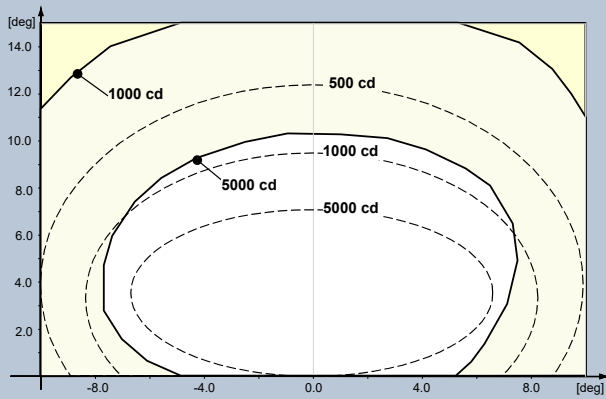

Fig. 1 ICAO Fig. A2-10 60 m – White

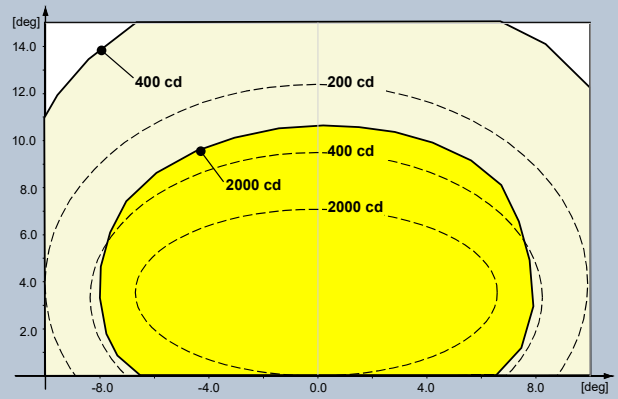

Fig. 2 ICAO Fig. A2-10 60 m – Yellow

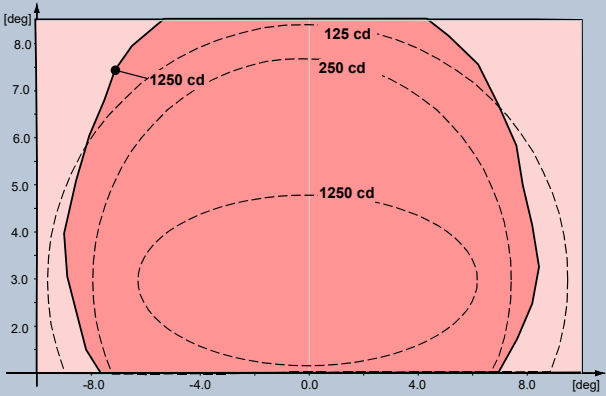

Fig. 3 ICAO Fig. A2-8 – Red

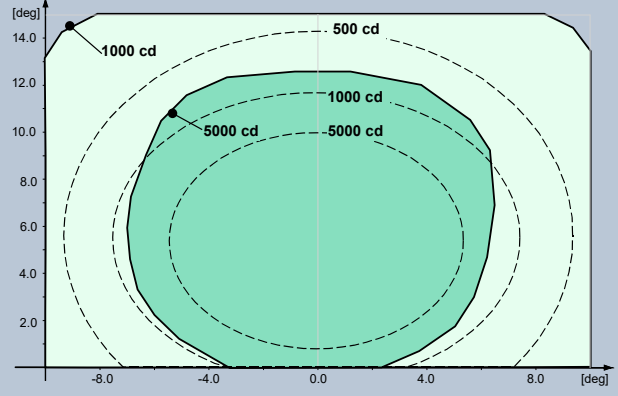

Fig. 4 ICAO Fig. A2-3 – Green

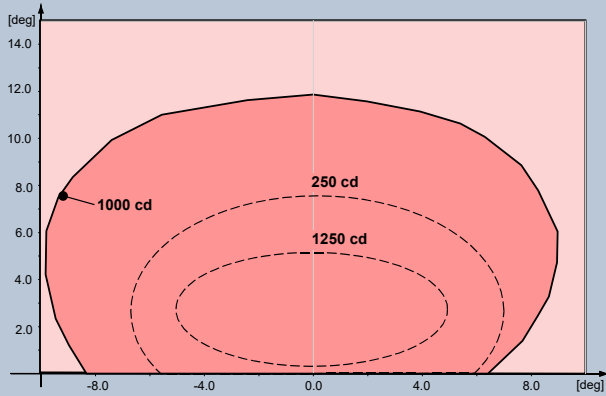

Fig. 5 FAA L-862E – Red

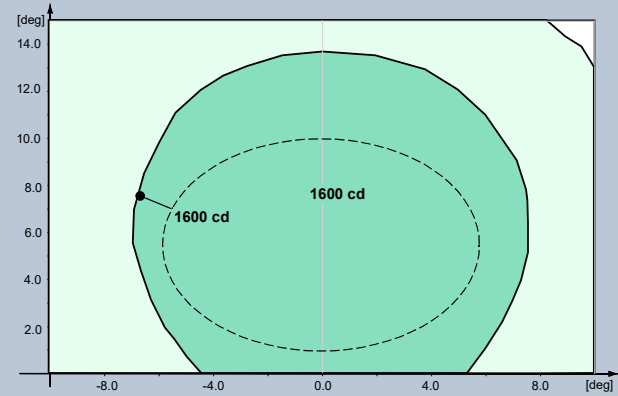

Fig. 6 FAA L-862E – Green

TABLES

POWER CONSUMPTION*

Electrical System	1 Plug
Bidirectional (without Arctic Kit)	35VA
Unidirectional (without Arctic Kit)	15VA
Bidirectional (with Arctic Kit)	52VA
Unidirectional (with Arctic Kit)	35VA

* Measured at 6.6 A and referred to the highest consumption configuration

POWER FACTOR

Input Step	2.8 A	6.6 A
Power Factor (without Arctic Kit)	0.96	0.98
Power Factor (with Arctic Kit)	0.99	0.99

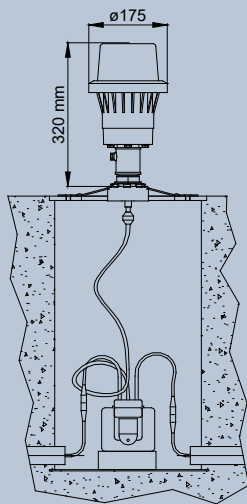
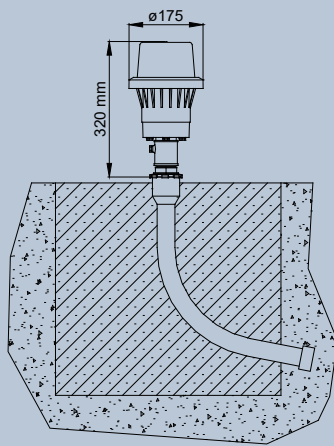
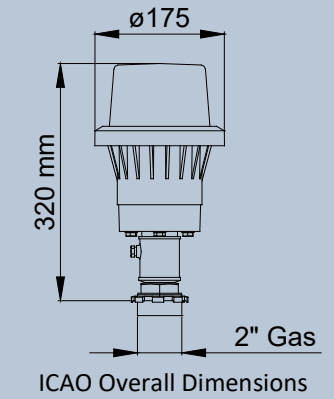

FAA L-867 Deep Base and Base Plate

LERE - F - T - WR - 14 - C - M - 0

Basic P/N: _____

Compliance: _____

- S = ICAO 45 m Runway Edge and Threshold/Runway End
- I = ICAO 60 m Runway Edge
- F = FAA

Use: _____

- T = Threshold/End
- E = Edge

Colour(Side L)/(Side R)*: _____

- W = White
- Y = Yellow
- R = Red
- G = Green
- M = No LED Source (unidirectional light)

Height: _____

- 00 = Without pole (mandatory for "I" and "S" Compliance) (**)
- 14 = 14"
- 20 = 20"
- 24 = 24"
- 30 = 30"

Breakable Coupling: _____

- A = 1" 1/2-12 UNF (for "14" to "30" Height)
- B = 2"-11 1/2 NPS (for "14" to "30" Height)
- C = 2"-11 GAS (mandatory for "00" Height)(**)
- D = 2"-11 GAS (for "14" to "30" Height)(**)(***)

Monitoring: _____

- 0 = Without Monitoring
- M = With Monitoring

Arctic Kit: _____

- 0 = Without Arctic Kit
- A = With Arctic Kit (option available only for FAA versions)
- * The beams aiming is not field adjustable
- ** Not defined by FAA.
- *** For snow areas, with EMT 1" pole.

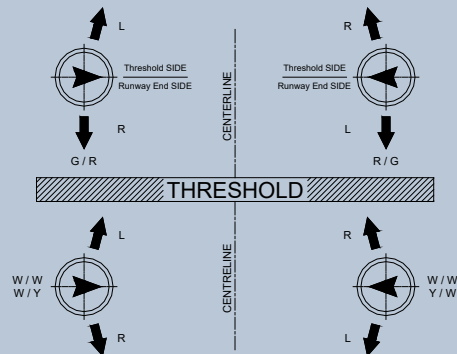

MAIN COMPONENTS OF THE LIGHT UNIT

- 1 Clear outer glass cover
- 2 Gasket for glass cover
- 3 LED module
- 4 Lens array
- 5 Glass cover locking ring
- 6 Body with electronic and plug
- 7 Breakable coupling with
- 8 Ring nut (ICAO versions)
- 9 FAA L-823 plug
- 10 Arctic Kit (option available only for FAA versions)

Refer to the relevant technical manual for the complete list of the available spare parts

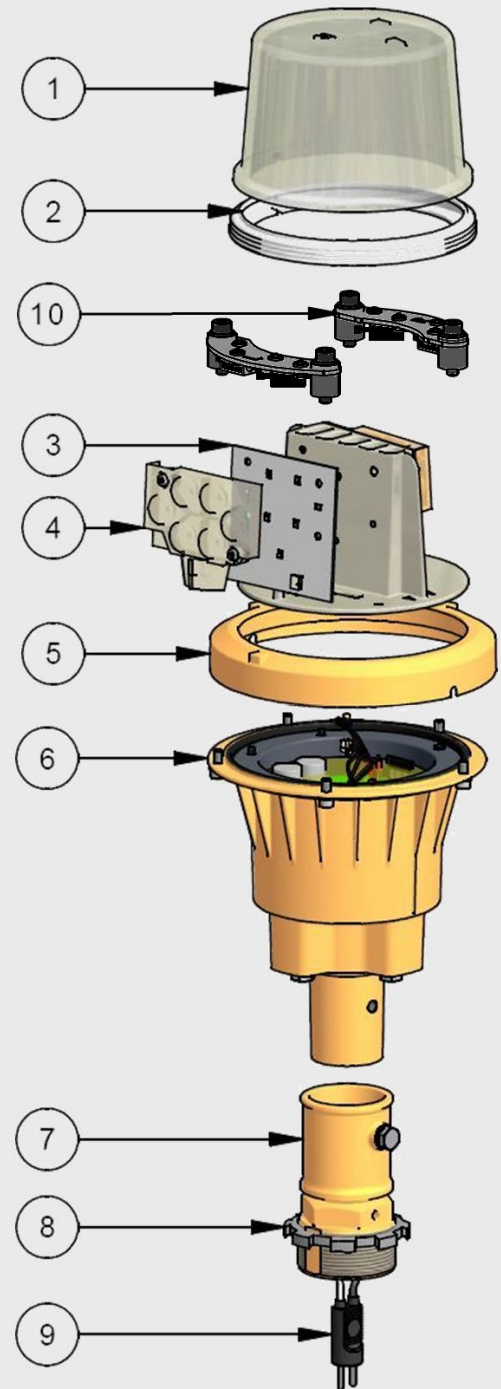
**ACCESSORIES**

- | | |
|----------|---|
| 013.0008 | Galvanized steel pipe elbow with upper threaded end only (2" - 11 GAS thread) |
| 315.3210 | Galvanized steel pipe elbow with both threaded ends (2" - 11 GAS thread) |
| 013.0010 | Set of two ryton rings for receptacle support inside pipe elbow |
| 315.1228 | Base L-867, Class IA, Size B, 24" Deep |
| 315.1062 | Baseplate for L-867 base with gasket and cable clamp (2"-11 GAS thread) |
| 315.1063 | Baseplate for L-867 base with gasket and cable clamp (2" - 11 1/2 NPS thread) |
| 315.1082 | Baseplate for L-867 base with gasket and cable clamp (1"1/2 - 12 UNF thread) |
| 332.4556 | Levelling device |

For any information about isolating transformers and connectors, please see the specific catalogue pages

Shipping Weights and Volumes

	Light Unit
Weight (kg)	5.0
Volume (m ³)	0.016